



Floway® Fire Pumps





# Floway® fire pumps are recognized worldwide for superior quality, top hydraulic performance and long service-life, providing reliability and fire protection when it counts.

Floway is a tier-one global supplier who understand the importance of your fire protection system. Our expertise in fire pumps stems over 50 years, during which time we have solely concentrated on vertical pump innovation.

Our Floway fire pump is designed to provide the best fire protection for your application. If a fire occurs, a reliable fire protection system is often the difference between major catastrophic damages or minor expenses due to property damage, destroyed records, and plant or factory downtime.

Floway fire pumps are designed and constructed in accordance with the National Fire Protection Association (NFPA) Standard, NFPA-20, and can be listed or approved by the following agencies:

- Underwriters' Laboratories, Inc. (UL/C-UL)
- Factory Mutual (FM)

## Our Capabilities

### Engineering Features

- Floway vertical fire pumps are manufactured in accordance with NFPA 20, NFPA 20 50 Hz and UL/FM standards
- Pressure ratings from 60 to 500 PSI
- Capacity ratings labeled from 250 to 5,000 USGPM (60-1140m<sup>3</sup>/hr)
- Greater than 50 feet for oil lubricated column and shaft assembly

### Testing

Testing includes a non-witnessed performance test with a laboratory driver and non-witnessed hydrostatic test of the pump components. Diesel engine driver and pump controllers receive non-witness tests per NFPA-20 at their points of manufacture. Witness testing and specific string testing are available upon request.

### Selection

We offer a full range of drivers, electric motors, diesel engines, and steam turbines for maximum versatility. Floway fire pumps are constructed to fit the right angle gear drive designs.

### Special Construction

- Stainless-steel and special alloy line shaft and coupling
- Flanged column sections
- Can-type pumps (positive suction pressure)
- Below-ground discharge head
- Skid packages
- Noise control engine enclosures
- Alternate starting and cooling methods

### Meeting Customer Needs

We work in close partnership with our customers to develop end-to-end engineering solutions to the technical challenges they face, delivering a genuine competitive advantage.



## Floway® Fire Pump Parts — Material Selection

Parts	316 Stainless Steel	Bronze Fitted	Duplex
Bowls	316 SS A743 316 SS	Ni-Al Brz B148 C95800	Super Duplex SS A890 6A
Impeller	316 SS A743 316 SS	Ni-Al Brz B148 C95800	Super Duplex SS A890 6A
Bowl w/r	316 SS A743 316 SS	Ni-Al Brz B148 C95800	Super Duplex SS A890 6A
Lineshaft, couplings and hardware	316 SS A276	Monel™ B164	Super Duplex SS A 276
Bearing	Marine bearing Phenolic/Rubber	Marine bearing Phenolic/Rubber	Marine bearing Phenolic/Rubber
Fabrications (column and head)	Coated Steel A36/A53	Ni-Al Brz B271 B148 C95800	Super Duplex SS A240/A790
Bolting	316 SS A193/A194	Monel™ F467/F468	Super Duplex SS A479
Stuffing box	Cast Iron A48 CL30	Ni-Al Brz B148 C95800	Super Duplex SS A890



# Floway® Vertical Turbine Fire Pump

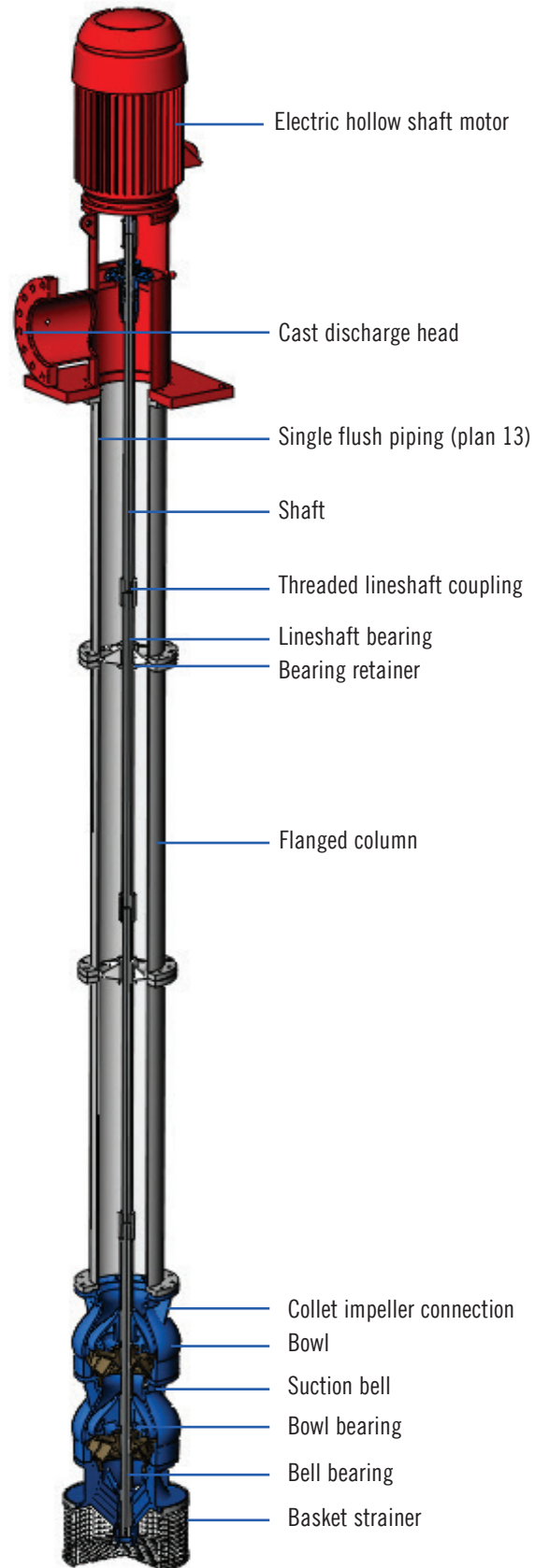
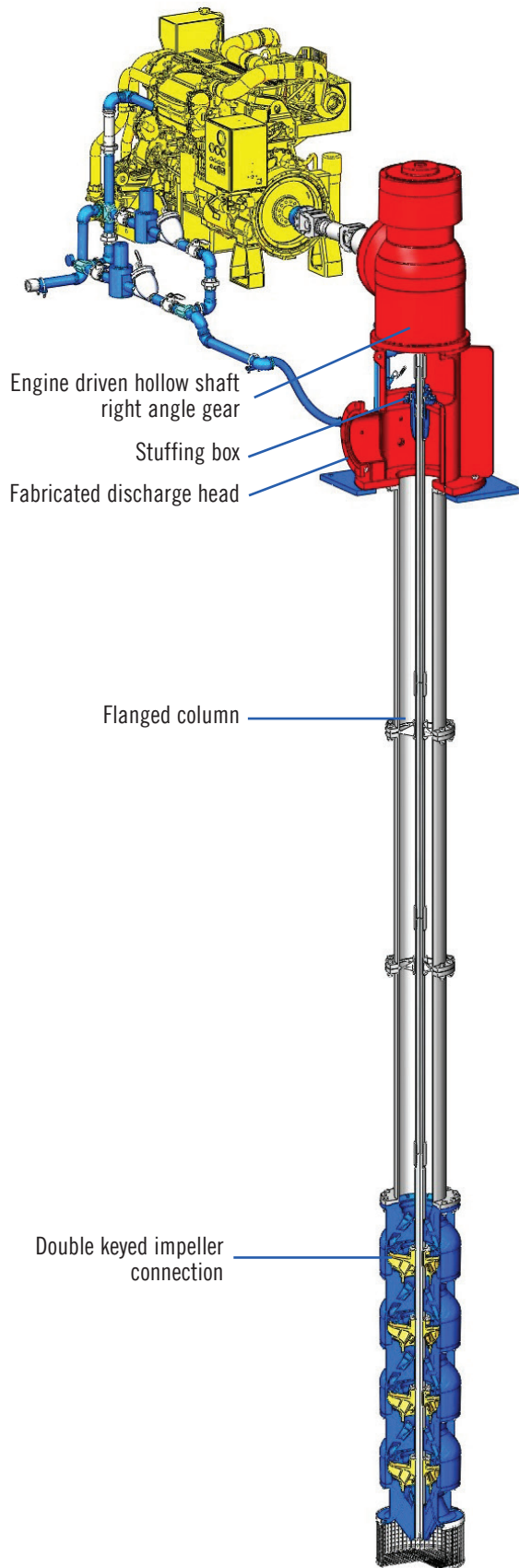



Trillium Pumps USA Inc.

2494 S Railroad Ave., Fresno, CA. 93706 USA

T 559 442 4000

F 559 442 3098

floway@trilliumflow.com www.trilliumflow.com

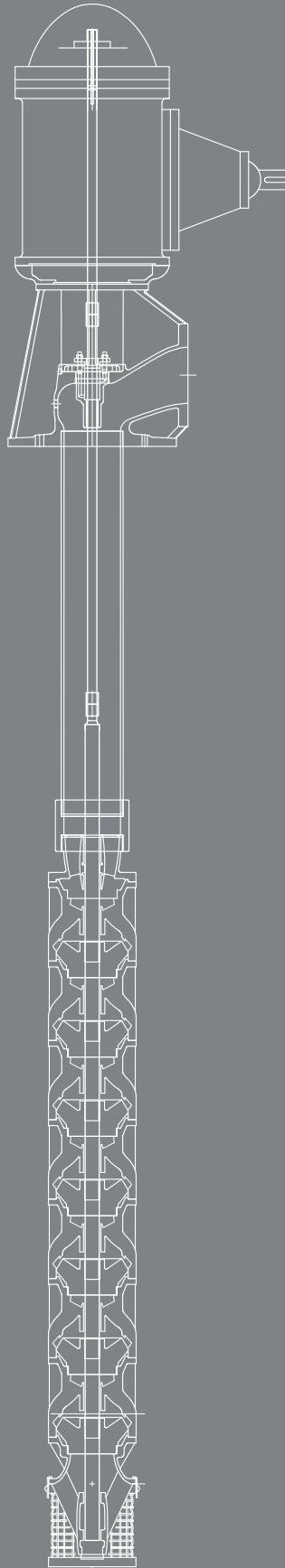

Copyright © 2017, 2019, Trillium Flow Technologies. All rights reserved.  
Floway is a registered trademark of Trillium Pumps USA, Inc.

Fire Pump Brochure  
Version 3, August 2019