

V series (Starsteam™)
Installation, Operation,
Maintenance Manual



CONTENT

1	SAFETY INSTRUCTIONS	3
2	SAFETY PRECAUTIONS	4
3	WARRANTY INFORMATION	5
4	TERMINOLOGY	6
5	GENERAL ADVICE	7
5.1	RESPONSIBILITIES.....	7
5.2	IDENTIFICATION PLATE.....	7
5.3	SPRING.....	8
5.4	STORAGE.....	9
5.5	HANDLING.....	9
6	STARSTEAM BASICS	10
6.1	DESCRIPTION.....	10
6.2	FEATURES AND NOMENCLATURES.....	11
7	INSTALLATION	14
7.1	GENERAL.....	14
7.2	INLET PIPING.....	14
7.3	OUTLET PIPING.....	15
7.4	INSTALLATION ON THE PROTECTED EQUIPMENT.....	15
7.5	OUTDOOR INSTALLATION.....	17
7.6	INDOOR INSTALLATION.....	17
7.7	COVER PLATE VENT PIPE.....	17
7.8	INLET BUTT-WELD END INSTALLATION.....	18
8	MAINTENANCE	25
8.1	DISASSEMBLY.....	26
8.2	INSPECTION.....	28
8.3	LAPPING.....	29
8.4	RE-ASSEMBLY (FULLY DISSASSEMBLED VALVE).....	32
9	TESTING	37
9.1	HYDROSTATIC TEST.....	37
9.2	SET PRESSURE AND ADJUSTMENT OF RINGS.....	39
9.3	CALIBRATION CHECK WITH ONLINE TESTING DEVICE.....	41
9.4	VALVE SEALING.....	41
10	MAINTENANCE TOOLS	42
11	TROUBLESHOOTING	43
12	SPARE PARTS	44
13	DISMANTLING	44
14	GENUINE PARTS	45
15	CODIFICATION	46

SAFETY SIGNS AND LABELS

Signs or labels are included throughout this document.

These signs or labels communicate the following messages:

- The level of hazard seriousness
- The nature of the hazard
- The consequence of human or product interaction with the hazard
- The instructions if necessary on how to avoid the hazard

The format is characterised by vertical panels. The panels include a signal word shown below which advises the level of hazard seriousness

- DANGER
- WARNING
- CAUTION
- ATTENTION

DANGER
Immediate danger which **WILL** cause serious personal injury or death.

WARNING
Risk or dangerous practice which **COULD** cause serious personal injury or death.

CAUTION
Risk or dangerous practice which **COULD** cause minor injuries.

ATTENTION
Risk or dangerous practice which **COULD** cause damage to equipment.

DANGER

<p>Never face the outlet of a valve when it is discharging as this may result in serious personal injury or death</p>

WARNING



<p>Be aware of all site safety procedures to prevent the risk of serious injury or death.</p>

CAUTION

<p>Protect yourself by wearing the necessary protective equipment to prevent possible injury.</p>

ATTENTION

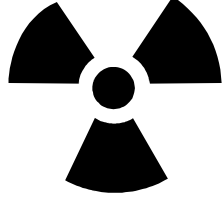
<p>Use the proper lifting equipment to avoid personal injury or damage to equipment.</p>

1 SAFETY INSTRUCTIONS



WARNING	CAUTION	ATTENTION
		
<p>Be aware of all site safety procedures to prevent the risk of serious injury or death.</p>	<p>Protect yourself by wearing the necessary protective equipment to prevent possible injury</p>	<p>Use the proper lifting equipment to avoid personal injury or damage to equipment.</p>

- In order that the product may work as expected, ensure that it has been correctly installed, it is being correctly used and it is correctly maintained and serviced.
- This document describes the main procedures which are necessary to satisfy to the essential safety requirements in order to operate the product correctly and to comply with the International rules and regulations for the specified pressure equipment.
- This document describes each essential step from the receipt of valves through the stages of installation, operation and service. It is mandatory to ensure that anyone intervening with the product, directly or indirectly, is fully aware of these steps. Pictograms are used to clearly advise of the potential dangers associated with the use of the product.
- Whilst this document is intended to be informative, it is important to understand that the safety messages provided are not exhaustive.
Trillium Flow Technologies cannot possibly be aware of, evaluate or advise, all of the conceivable methods by which tasks might be performed, or of the possible hazardous consequences of each of those methods.
Consequently, anyone who uses a procedure and/or tool, which is not recommended by Trillium Flow Technologies, or deviates from Trillium recommendations must be thoroughly satisfied that neither personal safety nor equipment safety will be jeopardized by the method and/or tools which have been selected.

The installation, operation and maintenance of safety valves could be dangerous. During these activities personnel might be exposed to direct or indirect injury risks from fluids which are at various high pressures and/or temperatures. Therefore, every precaution should be taken to prevent injury to personnel during the performance of any procedure.

Any person who uses a safety valve shall be trained in all aspects of handling, installation, operation and service.

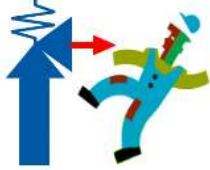
2 SAFETY PRECAUTIONS

DANGER	WARNING	CAUTION
		
<p>Never face the outlet of a valve when it is discharging as this may result in serious personal injury or death</p>	<p>Never dismantle a valve in line without making absolutely sure there is no remaining or residual pressure</p>	<p>Protect yourself by wearing the necessary protective equipment to prevent possible injury</p>

A safety valve is a self-acting product. Always consider the potential dangers associated with the product and never minimise them. Each plant or installation has its own safety rules. Be aware of them and follow them carefully.

- Never stand in front of the discharge side of a safety valve if the valve is operating or being tested.
- Always wear personal protective equipment (PPE): PPE should consist of but not be limited to ear protection, eye protection, and the use of protective clothing (gloves, headgear, etc). Noise can be extremely high and can occur suddenly. Steam and hot water can burn. Superheated steam is NOT visible.
- Always lower the operating pressure before making any adjustment to the valve. Always gag the valve before making any ring setting adjustments.
- Before removing a valve for disassembly, ensure that there is no remaining pressure upstream the valve and that the valve is isolated from the system pressure.
- Before performing each pop test on the safety valve, ensure that no personnel are close to the valve. The steam which could escape during the operation could cause serious personal injury.
- When a lift test is performed using the lifting lever, be sure to use a rope or a chain whilst standing at a safe distance away from the valve and any potential steam escapes.
- Valves under the operating pressure may relieve at any time. Never strike the body or tamper with the valve as such practice could cause premature relief.
- Never modify or change the valves, especially when they are under pressure. It is essential that you inform Trillium in ALL instances if any machining of parts is to be considered. Deviation from critical dimensions can adversely affect the performance of a safety valve.

3 WARRANTY INFORMATION

Trillium warrants that its products (including performance) and work will meet the specifications of the customer's Purchase Order. If any issue arises whilst operating the product, the customer should inform Trillium as quickly as possible. A return to the original plant should then be considered in order for Trillium to inspect the product.

Trillium cannot be held responsible for any incorrect sizing and selection of a valve if the original specification supplied by the customer was incomplete or inaccurate.

Trillium does not authorise any third parties (eg, non-Trillium service centres) to repair a product of Trillium's manufacture. Any customer allowing or sub-contracting the repair of a Trillium product which is still within its warranty period will do so entirely at their own risk.

4 TERMINOLOGY

For the purpose of this manual, the following abbreviations, definitions and terms apply.

ACCUMULATION

The pressure increase over the maximum allowable working pressure of the vessel, expressed in pressure units or as a percentage of maximum allowable working pressure (MAWP) or design pressure.

BACK PRESSURE

Back pressure is the static pressure existing at the outlet of a safety valve device due to pressure in the discharge system.

BLOWDOWN

The difference between actual popping pressure of a safety valve and actual reseating pressure expressed as a percentage of set pressure, or in pressure units.

CDTP (COLD DIFFERENTIAL TEST PRESSURE)

The pressure at which a safety valve is adjusted to open on the factory test bench.

The cold differential test pressure includes corrections for the service conditions of backpressure or temperature or both.

CHATTER

Rapid and erratic motion of the disc from closed to open position. This phenomenon can create damage to the valve internals, the main effect being on the disc and the nozzle components.

CLOSING PRESSURE

The value of decreasing inlet static pressure at which the valve disc re-establishes contact with the seat or nozzle, or at which the lift becomes zero.

LIFT

The actual travel of the disc away from closed position when a valve is relieving.

LEAK TEST PRESSURE

Leak test pressure is the specified inlet static pressure at which a quantitative seat leakage test is performed in accordance with a standard procedure.

MAWP (maximum allowable working pressure)

The maximum gauge pressure permissible at the top of a vessel in its normal operating position at the designated coincident temperature specified for that pressure.

OPERATING PRESSURE

The pressure at which protected unit is working and at which the safety valve should be tight.

OVERPRESSURE

The pressure increase over the set pressure of a safety valve, usually expressed as a percentage of the set pressure.

POPPING PRESSURE

The value of increasing inlet static pressure at which the disc moves in the opening direction at a faster rate as compared with corresponding movement at higher or lower pressures. It applies only to valves in compressible fluid service.

RESTRICTED LIFT

The lift arrangement to attain more effective control of the rated capacity of the valve. This is strictly certified by the National Board (USA) according the ASME B&PV Code Section I.

SET PRESSURE

Inlet gauge pressure at which the safety valve is set to open under relief conditions

SIMMER

The audible or visible escape of fluid between the seat and disc at an inlet static pressure below the popping pressure and at no measurable capacity.

5 GENERAL ADVICE

5.1 RESPONSIBILITIES

The recommended practices indicated within this manual must be respected to prevent any potential damage to goods. It is important that all points of advice are followed closely and are implemented by suitably qualified personnel. Trillium disclaims all responsibility for maintenance operations which may be performed by persons who are either not suitably qualified or are not considered to be an accepted part the Trillium organisation.

5.2 IDENTIFICATION PLATE

The data shown on the identification plate (figure 1) should be referenced with all requests for work, or for the supply of spare parts.

The identification plate bears the following information:

- Serial number (also stamped on the edge of the outlet flange)
- Safety valve type (model number)
- Inlet dimension - pressure class (rating)
- Outlet dimension - pressure class (rating)
- Orifice
- Set pressure with units
- Backpressure with units
- Identification number
- Spring identification number

EN ISO 4126-1 Ex II 2G&D		 TRILLIUM FLOW TECHNOLOGIES <small>10000 VANDERLINDEVALE, FRANCE</small>		MADE IN FRANCE		DIMENSION ORIFICE SIZE AND ORIFICE		LEVÉE LIFT		ANNEE YEAR	
				SURPRESSION OVERPRESSURE		SECT. PASSAGE FLOW AREA					
MODÈLE MODEL		RESSORT SPRING		COEF. DÉBIT CERT. CERT. FLOW COEF.		DÉBIT CERTIFIÉ CERT. CAPACITY					
P. DÉB. CONVENTURE SET PRESSURE		PRESSION RELÈVE COLD DIFF. TEST PRES.		N° SERIE SERIAL N°		REPERE TAG					
CONTREPRESSION BACK PRESSURE		TEMP. DÉCHARGE RELIEVING TEMP.		T. MIN °C T. MAX °C		MATIÈRE MATERIAL					

FIGURE 1

5.3 SPRING

The correct operation of a pressure relief valve depends upon its spring characteristics, resilience, and compression. Good pressure relief valve operation requires:

- Effective and accurate lift
- Sufficient flow rating
- Quick closing (no damping effect when reseating)

The adjustment range of the spring must be within $\pm 5\%$ of the nominal value

Spring data should be obtained from Trillium's Sarasin-RSBD Aftersales Department. When requesting information, please quote the serial number which is shown on the valve identification plate. Without this number, it may not be possible to identify the original valve.

5.4 STORAGE

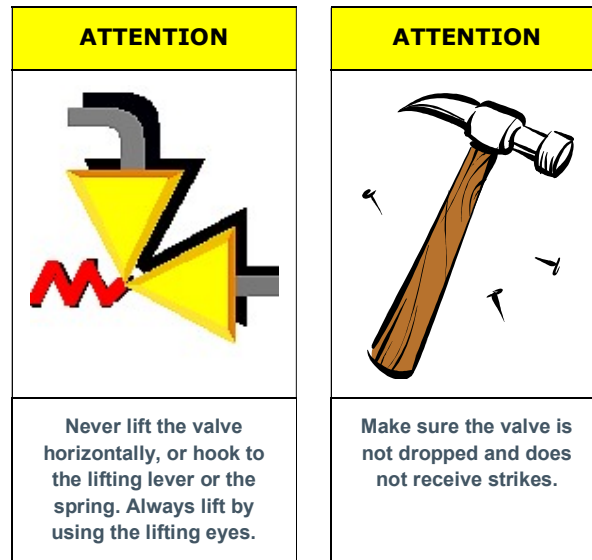

Safety valves may be received several months before an actual plant start-up date. In order that the valve performance is not adversely affected, it is important to follow some clear rules concerning storage and handling prior to installation.

- It is recommended that the safety valves are stored in a clean and dry environment, protected from weather conditions, the ingress of sand, dust, or any other solid particles or foreign matter.
- Wherever possible, the valves should be stored in their original packaging.
- Blanking plugs, thread protectors and plastic covers should only be removed at the point of installation of the valve.
- Special attention should be given to flange gasket contact surfaces and machined threads. Impact on these areas should be avoided.

5.5 HANDLING

The safety valve should be handled very carefully at all times whether they are in the packed or unpacked condition. The valves should never be subjected to any impact or striking, either directly or indirectly through the packaging.

Never lift or handle a safety valve by its lifting lever.

For V series (Starsteam™) safety valves, the use of slings is recommended. Slings should be attached to the lifting eyes in order to provide stability during handling.

The valve should be moved and transported in the upright position at all times to maintain performance accuracy.

6 STARSTEAM BASICS

6.1 DESCRIPTION

V series (Starsteam™) safety valves can be provided with either flanged or butt-weld inlet end connections. At the outlet side, the connection is always flanged.

Table 1 shows the critical flow path dimensions according to each orifice designation. In cases of restricted lift, values presented are the maximum allowable limitation.

ORIFICE DESIGNATION	ORIFICE DIAMETER		ORIFICE AREA		FULL LIFT		ASME CERTIFIED RESTRICTED LIFT		NON ASME CERTIF. RESTRICTED LIFT	
	(mm)	(inch)	(mm)	(inch)	(mm)	(inch)	(mm)	(inch)	(mm)	(inch)
1	28,6	1,167	6,43	0,996	7,15	0,281	3,9	0,155	2,1	0,084
2	37	1,510	10,75	1,667	9,25	0,364	5,1	0,200	2,8	0,109
3	47,2	1,927	17,79	2,758	11,8	0,465	6,5	0,256	3,5	0,139
4	57,2	2,335	25,70	3,983	14,3	0,563	7,9	0,310	4,3	0,169
5	66	2,694	34,21	5,303	16,5	0,650	9,1	0,357	5,0	0,195
6	76,2	3,110	45,61	7,069	19,1	0,750	10,5	0,413	5,7	0,225
Q	95,3	3,890	71,33	11,056	23,8	0,938	13,1	0,516	7,1	0,281
R	114,3	4,665	102,61	15,904	28,6	1,125	15,7	0,619	8,6	0,338
RR	125,9	5,139	124,49	19,296	31,5	1,239	17,3	0,682	9,4	0,372
T	150	6,122	176,72	27,391	37,5	1,476	20,6	0,812	11,3	0,443

TABLE 1

A sectional view of the V series (Starsteam™) safety valve is shown on page 18 of this document.

The valve consists of a body and inlet connection which is mounted on the pressurized system. A disc (11) is held in place against the nozzle (6) to prevent any flow under normal system operating conditions and a spring (46) is used to hold the disc firmly on to the nozzle seat.

The disc (11) which is screwed on to the spindle (13) is held in place by the disc nut (26) and the disc-holder (56). The disc holder is inserted into the guide (9) with two sliding rings (12). Each of these rings are made up of two segments which allow them to be mounted around the disc-holder. This arrangement is referred to as the anti-seizing function.

Three rings allow accurate adjustment of the popping and the reseating pressure: a lower adjusting ring (7), an upper adjusting ring (8) and an overlap ring (28) which is at the cover level. A lift stop (10) controls the lift characteristics.

The sub-assembly, ie, disc nut (16), lift stop (10) and overlap ring (28) are prevented from rotating by the use of cotter pins. Upper and lower adjusting ring screws (22) and (23) prevent the rotation of the lower adjusting ring (7) and upper adjusting ring (8).

The spring (46) load is adjustable by using the set screw (14) to ensure control of the pressure at which the valve opens. A thrust bearing (104) protects the valve setting avoiding any rotation of the spindle or the disc. This feature protects the seat during any adjustment.

The lifting lever (30) is connected via the cap (5) to the spindle (13) and the disc (11). This device is mandatory in accordance with the ASME code to periodically test the safety valve.

The drain plug (34) allows draining of fluid from the lowest available point of the body (1).

6.2 FEATURES AND NOMENCLATURES

Body design in accordance with ASME B16.34

- ASME B&PV Code section I design
 - 3% overpressure
 - Adjustable blowdown in between -2% and -4%
- Semi nozzle design
- Body inlet connection : Flanged or Butt-weld
- Pressure rating : from class 600 to class 4500
- Anti-seize feature
 - Two Thermoglide™ rings on the piston and one in the set screw
- Restricted lift arrangement
 - Adjustable lift stop to attain either a full lift or a restricted lift
- Premium tightness performance
 - Stardisc™ low-loading point and a lip design which increases the tightness on high pressures and high temperatures applications.
 - Stardisc™ supplied in Alloy 718.
- Blowdown chamber
 - Allows a short blowdown adjustment
 - Allows a fast blowdown speed to protect the seat from high steam velocity when reseating

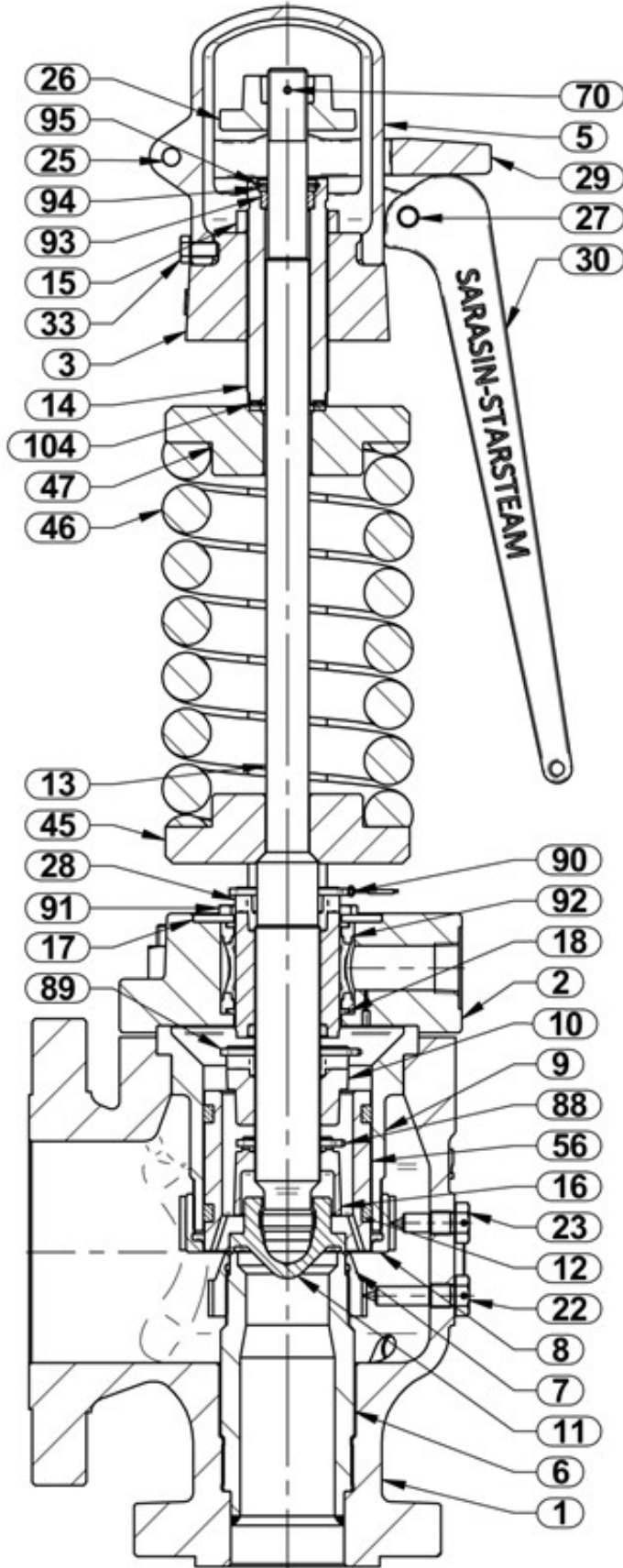

PART	DESCRIPTION	SPARE PARTS
1	BODY	E
2	COVER	E
3	YOKE	E
5	CAP	E
6	NOZZLE	E
7	LOWER ADJUSTING RING	B
8	UPPER ADJUSTING RING	B
9	GUIDE	C
10	LIFT STOP	B
11	STARDISC	A
12	SLIDING RING	A
13	SPINDLE	B
14	SET SCREW	D
15	SET SCREW NUT	D
16	DISC NUT	B
17	FLOATING WASHER RETAINER PLATE	C
18	FLOATING WASHERS	C
20	ROD	E
22	LOWER ADJUSTING RING SCREW	B
23	UPPER ADJUSTING RING SCREW	B
25	FORK PIN	D
26	SPINDLE NUT	D
27	LEVER PIN	D
28	OVERLAP RING	B
29	FORK	D
30	LEVER	D
33	CAP SCREW	D
34	DRAIN PLUG	D
35	COVER STUD	D
45	LOWER SPRING WASHER	C
46	SPRING	C
47	UPPER SPRING WASHER	C
50	ROD NUT	D
56	DISC HOLDER	C
60	COVER NUT	D
70	SPINDLE NUT COTTER PIN	A
86	PIN CIRCLIPS	A
87	PIN WASHERS	A
88	DISC NUT COTTER PIN	A
89	LIFT STOP COTTER PIN	A
90	OVERLAP RING COTTER PIN	A
91	RETAINER PLATE SCREWS	C
92	SPACER	D
93	SPINDLE RING	A
94	SET SCREW WASHER	C
95	SET SCREW CIRCLIPS	B
104	THRUST BEARING	C

TABLE 2

FIGURE 2

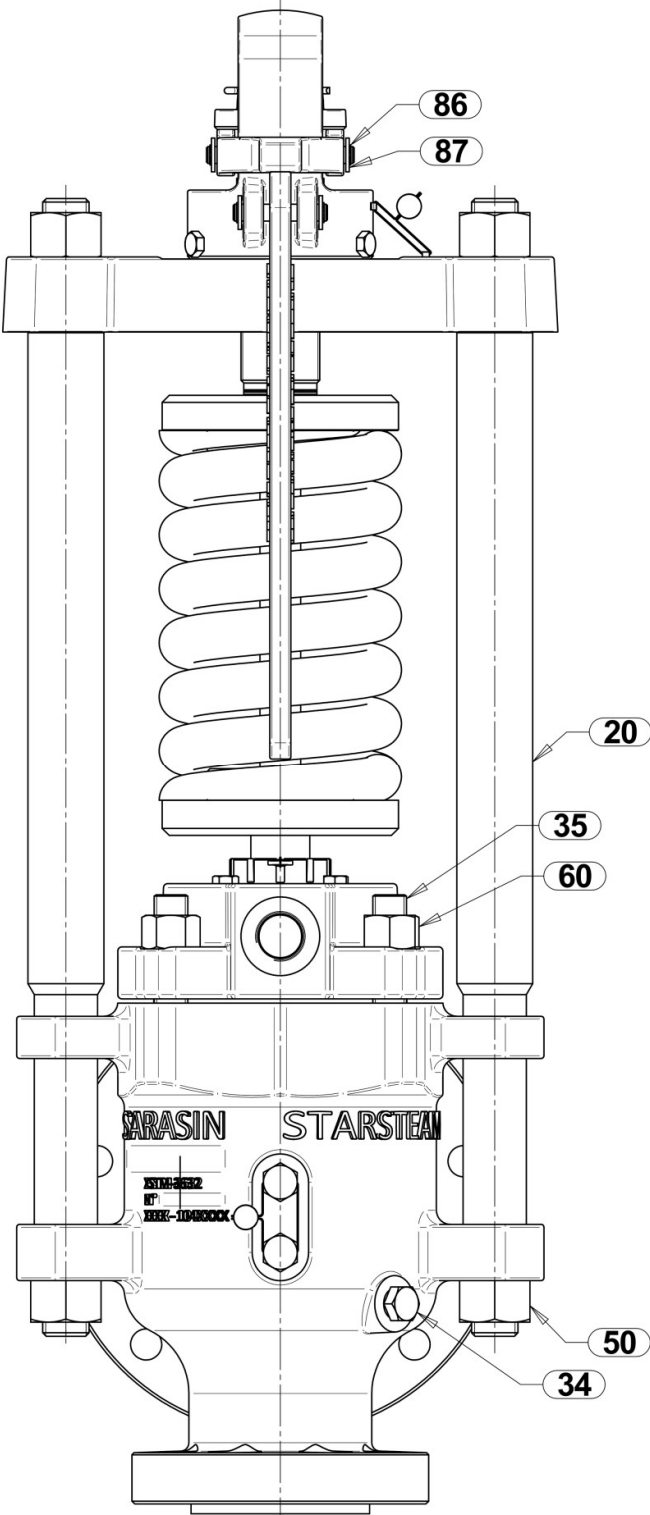

For restricted lift applications, the V series (Starsteam™) safety valves have the following plate fitted on the cover.

⊕ RESTRICTED LIFT ⊕

FIGURE 3

7 INSTALLATION

7.1 GENERAL

<p style="text-align: center;">DANGER</p> 	<p style="text-align: center;">WARNING</p> 	<p style="text-align: center;">CAUTION</p> 	<p style="text-align: center;">CAUTION</p> 
<p>Never face the outlet of a valve when it is discharging as this may result in serious personal injury or death</p>	<p>Be aware that the environment might be very extremely hot. Care should be taken if there is any potential steam leakage. Superheated steam is invisible.</p>	<p>Protect against the high noise levels which occur during popping tests. Keep a safe distance when the test is being performed.</p>	<p>Helmets and gloves must be worn to prevent any injuries while operating or working on the valve.</p>

Piping systems and equipment through which the fluid flows must be thoroughly cleaned. Dust, deposits and metal particles must be removed using controlled blasts of compressed air or steam.

The presence of any solid particles between the safety valve and its seat faces will have damaging effects. Any leak will lead to improper functioning and erosion of the seating surfaces. Such erosion develops quickly, due to the high pressure. The system should always be purged before safety valve is installed.

Prior to installation of the safety valves, all protective covers must be removed. It is recommended that any surfaces in contact with gaskets are checked. Dimensions of gaskets should be checked: gaskets must not obstruct inlet or outlet orifices.

A pressure relief valve will only operate correctly if all installation procedures are observed.

7.2 INLET PIPING

If the inlet pressure drop is excessive, it may generate chattering effect during operation of the valve. Chattering may in turn be the cause of seat damage, or spindle deformation.

In order to avoid chattering, the following recommendations should be followed to reduce pressure drop:

- A rounded concentric reducer from the boiler will create a minimum of turbulence.
- The inlet piping must be as short as possible and direct.
- A safety valve must not be installed on piping which has a nominal diameter of less than the nominal inlet diameter of the safety valve.
- The safety valve must not be subjected to excessive vibration which might be transmitted by the installation.

7.3 OUTLET PIPING

The safety valve must not support either the weight or the installation stresses of the outlet piping.

The backpressure should be reduced by using outlet piping with a nominal diameter of at least one size greater than the nominal diameter of the safety valve outlet flange, together with large radius elbow.

Recommendations

- The inside diameter of the exhausting piping must not be less than that of the safety valve outlet orifice.
- Release should be in the upwards direction and, a means of draining must be available in the lower angle to prevent any accumulation in the body.
- The connection curve to the vertical piping must be as close as possible to the safety valve outlet flange. The easiest solution is for the elbow to be bolted directly to the safety valve flange.
- The radius of the elbow must be as great as possible, ie, at least $R \geq 2.5 d$.

7.4 INSTALLATION ON THE PROTECTED EQUIPMENT

The equipment nozzle on which the safety valve is to be connected must be designed to give direct flow. There must be no obstruction between the equipment and the safety valve.

The pressure relief valve must be mounted on the upper part of the equipment which it is to protect.

Recommendations

- The safety valve must always be installed in the vertical position.
- The safety valve must be subjected to no stresses whatsoever from piping, connections or drains.
- The use of reinforcement should be considered for the inlet piping connections, to support dynamic loading which might be caused by reaction forces at the outlet connection.
- For maintenance operations, it is necessary to have sufficient space around and above the safety valve to perform essential tasks.

In the case of long outlet piping, and in order to achieve full safety requirements, the piping should be designed to accommodate a drip pan or drip tank - see figure 4. Such an arrangement will considerably reduce stresses between the piping and its support.

The safety valve body must be permanently drained, by connecting the drain orifice on the lower part of the body, to that on the drip tank or drip pan. The connection thread is 1/2" NPTF.

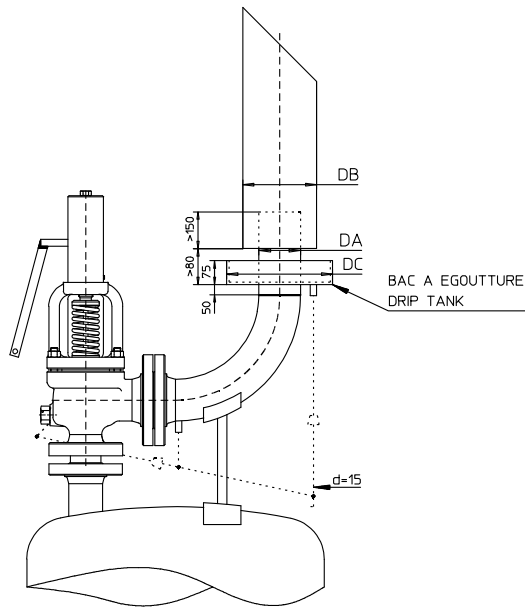

DA (mm)	DB (mm)	DC (mm)
25	50	150
40	80	200
30	80	200
66	100	220
80	150	270
100	150	270
150	200	320
200	250	370
250	300	420

TABLE 3

FIGURE 4

It is necessary to use a torque wrench to tighten the inlet and outlet flange bolting.

1. A check should be made that the gasket is centered on the flange
2. Tighten to 30% of the nominal torque according to the following figures:

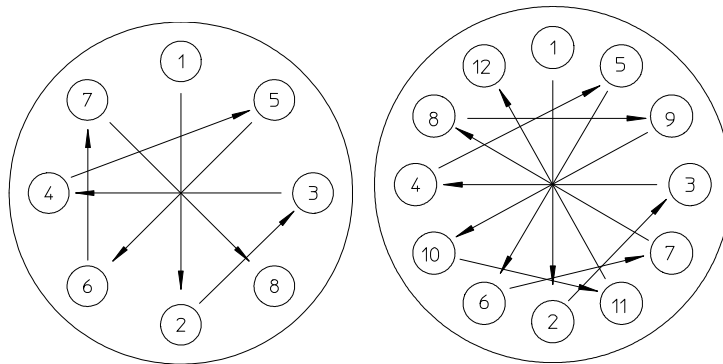

FIGURE 5

Continue to tighten alternatively until the required torque is reached. This should be done in 3 or 4 steps.

NOTE: Due to the relaxation of the gasket, it should be checked it 24 to 48 hours after the first installation.

7.5 OUTDOOR INSTALLATION

A safety valve which is installed outdoors must be protected against any inclement environmental conditions to ensure that it will provide the highest level of safety and will operate in the most effective & responsive manner.

If the safety valve is exposed to hazardous weather conditions, ingress of dirt or other foreign matter or any extremes of temperature conditions, please ensure that:

- The body is insulated from the inlet neck to the cover. Excessive variations in temperature may affect the set pressure or the body structure (thermal stress).
- A weathershield is fitted to prevent ice or snow accumulation or any foreign particles being trapped between the spring coils. A weathershield may also be used to protect the spring against sea or ocean spray.

7.6 INDOOR INSTALLATION

The outlet of the safety valve should not be connected to any equipment which might allow steam to be ejected through the top cover and might in turn add risk of injury to personnel working close to the valve.

7.7 COVER PLATE VENT PIPE

The steam escaping from the cover plate vent hole can vent to the atmosphere. It must vent to a safe area to avoid injury to personnel who might be working close to the valve.

To ensure the valve operates at maximum safety:

- The vent hole should never be plugged
- The size of the vent hole should never be reduced from its original size.
- In case a drain pipe is connected to the vent hole, it must be made in such a way that there is no risk of steam condensate accumulation.

7.8 INLET BUTT-WELD END INSTALLATION

Safety valves which are supplied with butt-weld inlets come with a hydrostatic test plug. This plug is used for hydraulic testing of the valve.

7.8.1 RECEPTION, WELDING & HYDRO TESTS

Packaging

- The safety valve with BW (Butt-Weld) inlet end will be shipped with its hydrotest plug installed.
- Trillium recommends that the safety valve should remain in its closed packaging until the time of installation.
- The packaging should not be opened until the welding phase has occurred.
- This will prevent dirt, humidity, ocean spray and other foreign particles making any contact with the valve internal parts.

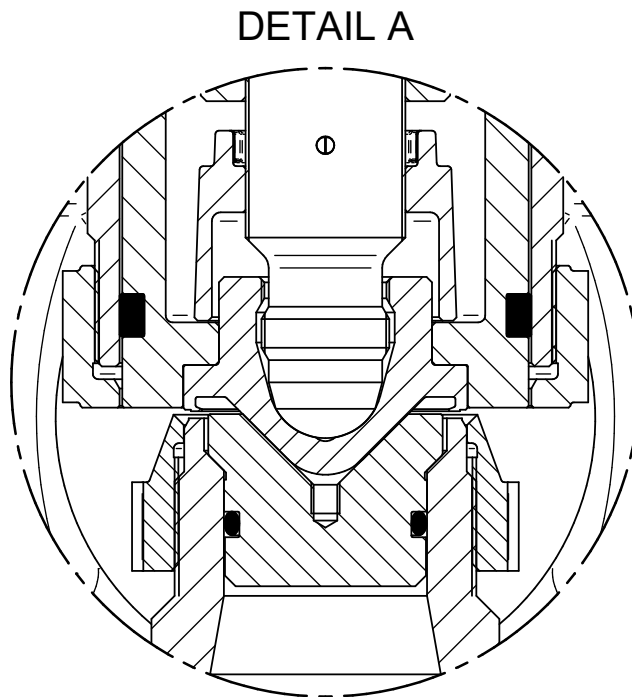

FIGURE 7

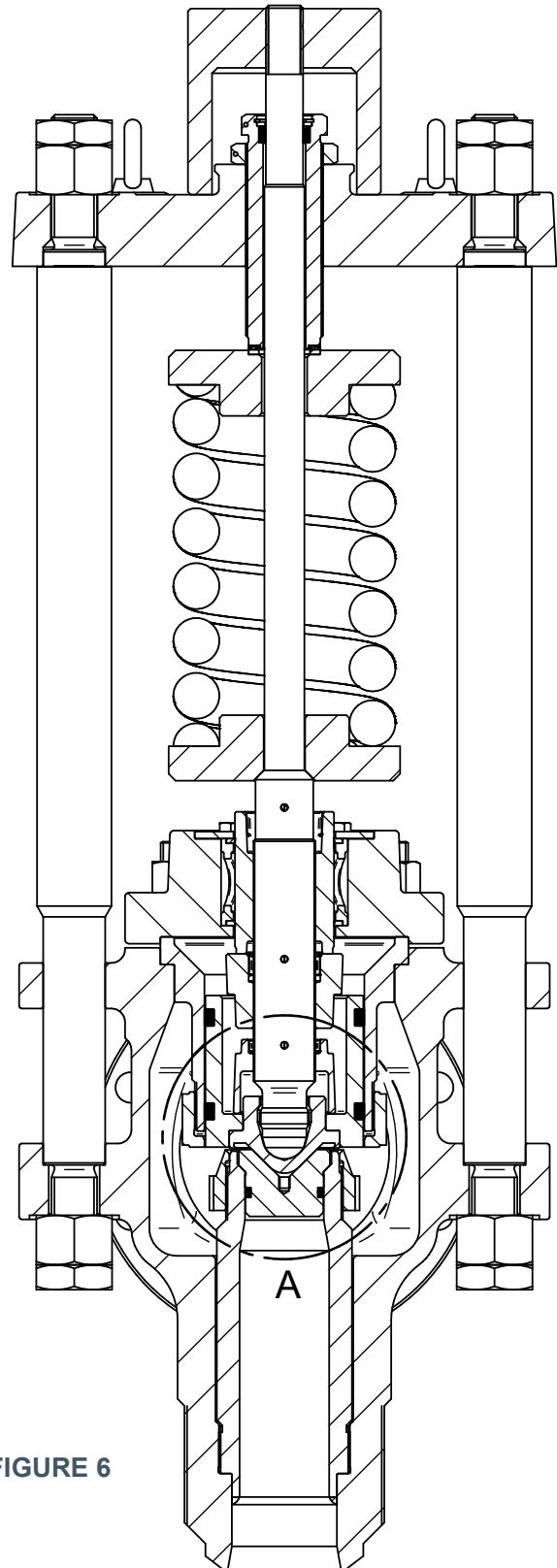

FIGURE 6

Welding

- Upon opening the box, the safety valve should be lifted and handled in a vertical position
- Before any welding is carried out to the valve body, **ENSURE THE GROUND PLUG OF THE WELDING EQUIPMENT IS NOT TOUCHING THE SAFETY VALVE.**
- Sparks can cause damage to the sealing areas and current transmission can weld internal parts together which will lead to troubleshooting of the safety valve.

Hydrostatic testing of the weld

- After welding and all necessary controls have been completed, it is possible to proceed to hydrostatic testing stage.
- The hydrotest plug is designed to be able to hold 1.5 times the set pressure.

7.8.2 HYDRO PLUG REMOVAL & VALVE PREPARATION

For these operations, it is recommended to contact TRILLIUM France or any other authorized TRILLIUM partner to support with the valve preparation.

Hydrotest plug removal

- Once the hydrostatic tests have been completed, it is required to make sure that the pressure has been completely bled off the equipment (drum, tank, etc.)
- Unscrew the spring compression locknut to create a clearance which allows **3 mm to 5 mm between the yoke and the spring compression locknut.**

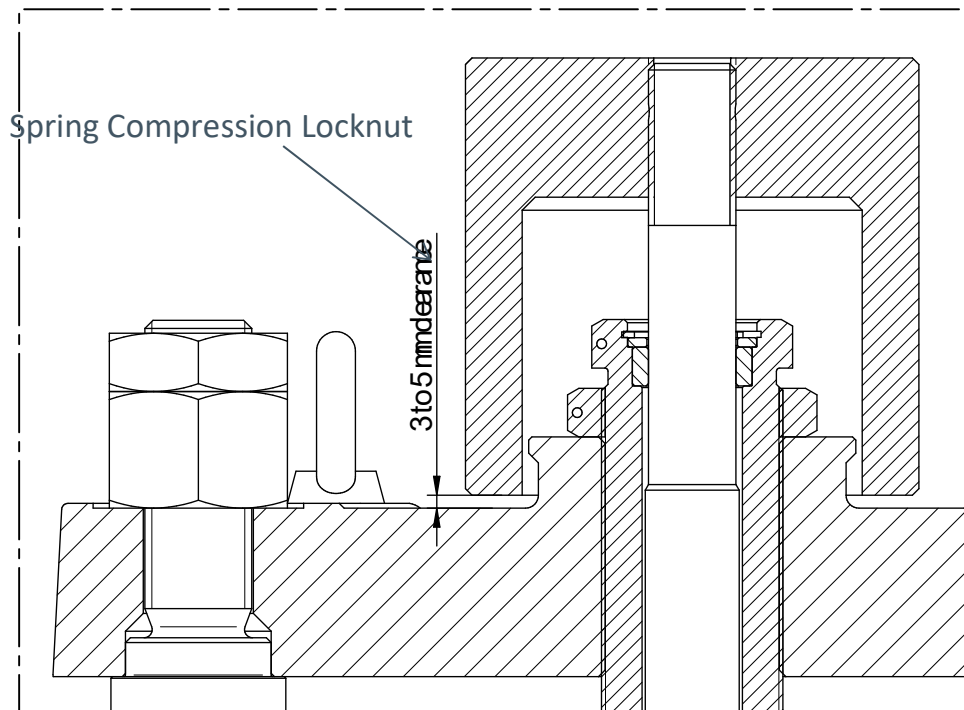

FIGURE 8



- Then, unscrew the 2 lower rod lock nuts (51).
- Unscrew the 2 lower rod nuts (50) by $\frac{1}{2}$ turn until the spring compression locknut is in contact with the yoke (3).
- Then, unscrew and remove the 2 lower rod nuts (50).
- Unscrew the 4 body plate nuts (60).

Note: If the access to the lower rod nuts is difficult to reach, you still can do the same operation from the top to lift the valve trim without the rods.

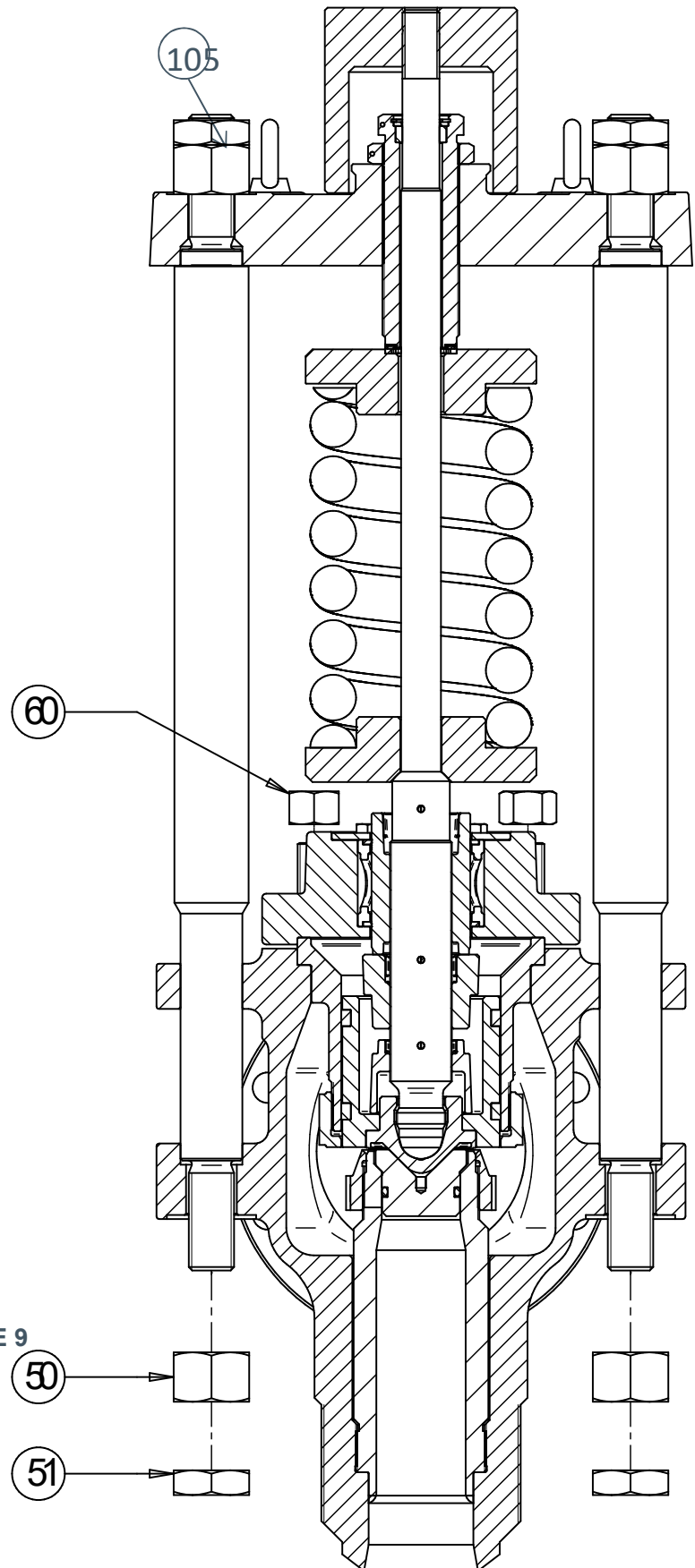

FIGURE 9

50

51

ROD NUTS THREAD SIZES :

Orifice	Class	Thread
1	600	M22
	900	M22
	1500	M22
	2500	M22
	4500	M22
2	600	M22
	900	M30
	1500	M30
	2500	M30
	4500	M30
3	600	M33
	900	M33
	1500	M33
	2500	M33
	4500	M33
4	600	M33
	900	M36
	1500	M36
	2500	M36
	4500	M36
5	600	M36
	900	M36
	1500	M36
	2500	M36
6	600	M42
	900	M42
	1500	M42
	2500	M42
Q	600	M48
	900	M48
	1500	M48
R	600	M48
	900	M48
	1500	M48
S	600	M48
	900	M48
	1500	M48
T	600	M52
	900	M52
	1500	M52

- Lift the valve trim by using the 4 lifting eye bolts (105).
- **!!! Be careful that the guide (09) doesn't come with the the whole trim !!!**
- It is essential to keep the safety valve superstructure vertically in order to prevent the 2 sliding rings (12) falling and being damaged.
- Remove the hydrotest plug. The threaded hole in the plug may be used to remove the hydro plug.

Orifice	Thread
1 - 2 - 3 - 4 - 5 - 6	M8
Q-R-RR-T	M10

TABLE 4

HAZARD ! Do not try to loosen the spring compression locknut (107.4) before completing the reassembly. The spring (46) can easily be forced out of the assembly and may cause injury (or death) to personnel.

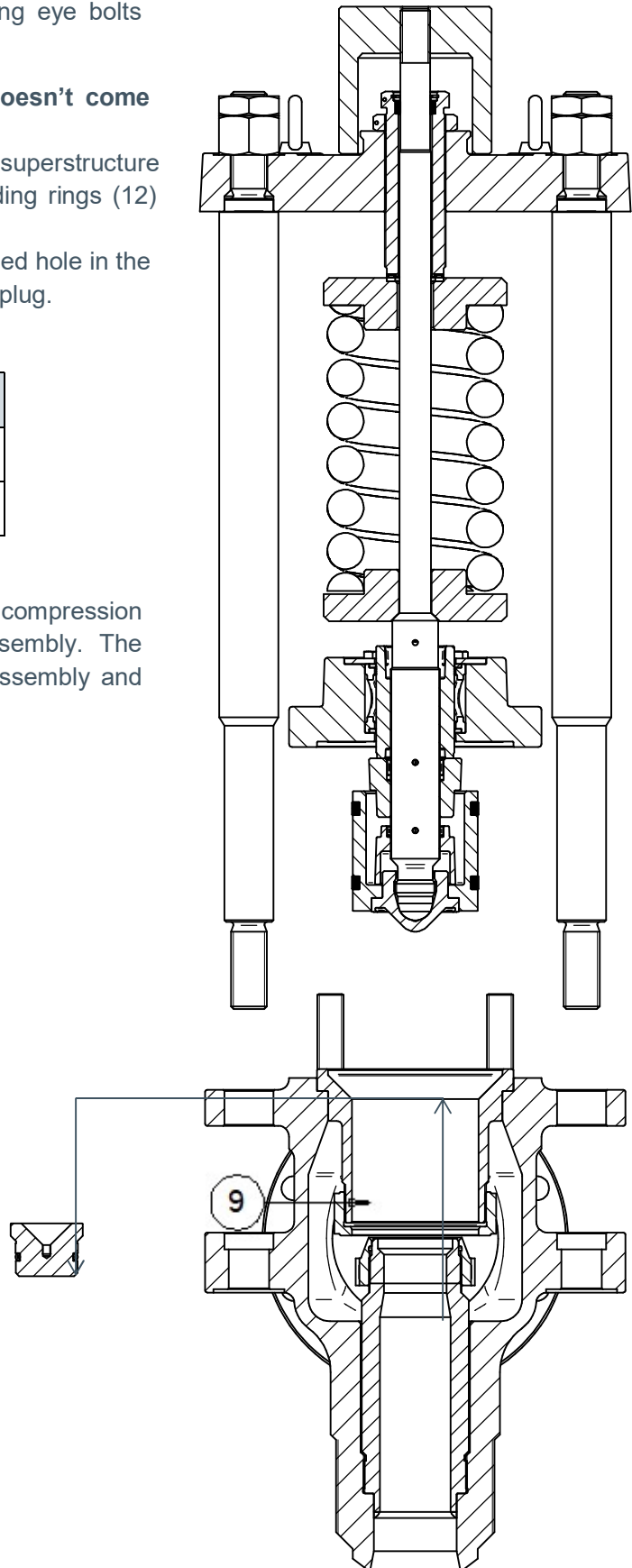

FIGURE 10

Valve Reassembly

- Carefully check that all those parts fit properly one in another :
 - The disc holder (56) inside its guide (9)
 - The rods (20) inside the body ears (1),
 - The cover (2) onto its studs (35).
- Gently lower the valve trim until the disc (11) makes contact with the nozzle (6).
- Screw the 2 lower rod nuts (50) by ½ turn until the rods (20) are in contact (locked) with the body (1).
- The spring compression locknut shall then safely be unscrewed till being loose..
- Then, screw the 2 lower rod lock nuts (51).
- Screw back the 4 body plate nuts (60).
- Use the table 5 for required torques which should be applied.
- Remove the spring compression locknut.

HAZARD ! Do not try to loosen the spring compression locknut before completing the reassembly. The spring (46) can easily be forced out of the assembly and may cause damage to personnel with potentially lethal consequences.

NOTE : for the valve popping point and rings adjustments, please refer to section 9.2.

Lifting lever assembly

- Insert the spindle nut (26) into the lifting lever assembly.
- Fit the assembly over the yoke (3) and then screw the spindle nut (26) on to the spindle (13).
- Screw the 3 cap screws (33) on to the yoke (3).
- Screw down the spindle nut (26) until it reaches the fork (29). Then unscrew it once again to maintain a clearance of 1mm between the spindle nut (26) and the fork (29). Lock the spindle nut (26) in place using the spindle nut cotter pin (70).
- The safety valve is now completely reassembled and is ready for commissioning.

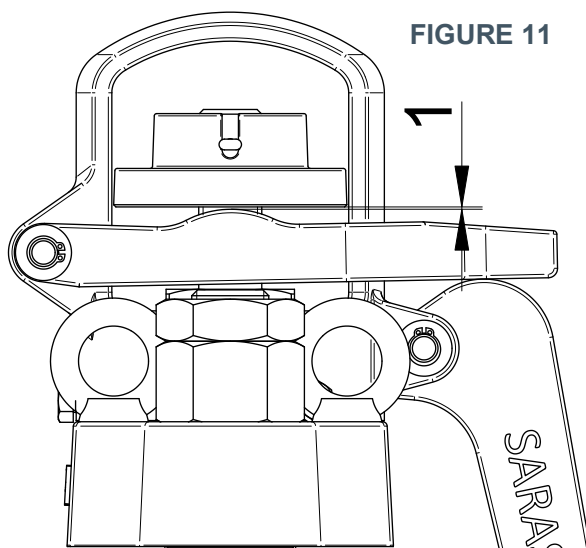
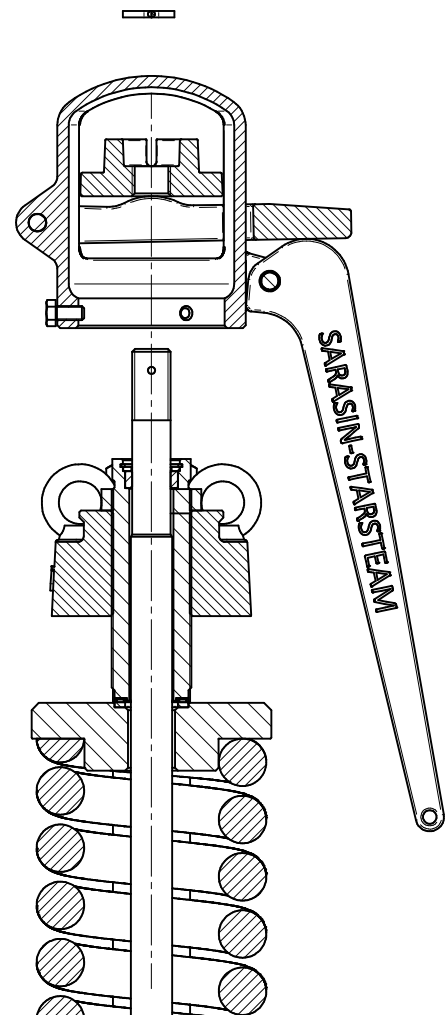

FIGURE 11

FIGURE 12





Nominal diameter (mm)	Core section (mm ²)	Allowable stress (M.Pa)		Tightening torque (m.daN)	
		Carbon steel <i>Exemple : B7/L7 42CD4</i>	Stainless steel <i>Exemple : B8 Z6CN18.9</i>	Carbon steel <i>Exemple : B7/L7 42CD4</i>	Stainless steel <i>Exemple : B8 Z6CN18.9</i>
10	52.3	172	152	1.7	1.5
12	76.2	172	152	3.0	2.6
14	105	172	152	4.7	4.2
16	144	172	152	7.2	6.4
18	175	172	152	10.0	8.8
20	225	172	152	14.1	12.5
22	281	172	138	19.1	15.3
24	324	172	138	24.4	19.6
27	427	172	113	36.0	23.7
30	519	172	113	49.0	32.2
33	647	172	113	66.5	43.7
36	759	172	88	85.6	43.8
39	913	172	88	111.2	56.9
42	1040	172	88	85.6	43.8
45	1220	172	88	170	87
48	1370	172	88	204	104
52	1650	172	88	365	187

FRICTION COEFFICIENT (ASSEMBLING WITH GREASE) = 0.15

TABLE 5

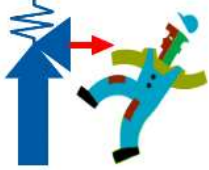
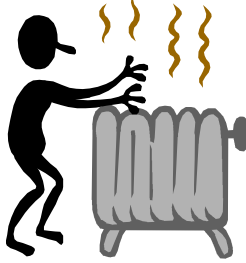
8 MAINTENANCE

DANGER	CAUTION	CAUTION
		
<p>Never face the outlet of a valve when it is discharging as this may result in serious personal injury or death. There should be zero pressure at the valve inlet prior to commencement of any work which is to be performed.</p>	<p>Any person who is working on the valve should be aware of any potential dangers such as retained heat)</p>	<p>Helmets and gloves must be worn to prevent any injures while operating or working on the valve.</p>

No particular tool is required for the maintenance operations on the V series (Starsteam™) valve. Maintenance may be performed without taking the valve off line. Please contact Trillium Sarasin-RSBD after-sales team in the event of any uncertainty.

Prior to performing any maintenance operation, the system upon which the safety valve is installed must not be pressurised.

8.1 DISASSEMBLY

8.1.1 COMPLETE DISASSEMBLY

Cap assembly

- Remove the lifting lever (30) taking out the lever pin (27) the pin circlips (87) and washers (86).
- Remove the fork (29) taking out the fork pin (25) the pin circlips (87) and washers (86).
- Unscrew the three cap screws (33) and take out the cap (5).
- Remove the spindle nut (26) by taking out the spindle nut cotter pin (70).

Spring assembly

- Before unloading the spring assembly, measure the spring (46) height between washers (45) and (47). In order to get a second check point, it is recommended to apply a mark with a pen on the set screw (14) and the yoke (3) and then to count the amount of full turns which are required to unload the spring.
- Unscrew the set screw locknut (15).
- Unscrew the set screw (14) taking it from the yoke (3) and the set screw nut (15).
- When the spring is unloaded, unscrew totally the four rod nuts (50) from the rods (20) and remove it from the valve.
- Remove the spindle (13) the yoke assembly {(3); (14) + (93) + (94) + (95); (15)}, the spring assembly {(45); (46); (47) + (104)} and the rods (20).

Cover assembly

- Before removing the cover assembly {cover (2); floating washer retaining plate (17); floating washers (18); retainer plate screws (91); and spacer (92)}, mark off the overlap ring position (28) on the spindle (13) with a pen.
- Take out the pin (90) in order to remove the cover assembly. To do this, unscrew the body plate nuts (60) to be able to uncouple the studs (35).
- Remove the cover assembly (2).

Spindle assembly

- Remove the spindle assembly {spindle (13); overlap ring (28); lift stop (10), lift stop cotter pin (89); disc nut (16), disc nut cotter pin (88), disc (11), disc holder (56) and sliding rings (12)} from the body (1).
- Remove the sliding rings (12) from the disc holder (56).
- Unscrew the disc (11) from the spindle (13) to release the disc holder (56).
- It is not necessary to remove the lift stop (10) or the overlap ring (28).

Guide and adjusting ring

- Note the position of the upper adjusting ring (8) (by marking axially on the guide (9) and the ring). This will quickly help to find the original position prior to disassembly. Unscrew the upper adjusting ring screw (23) in order to unlock the upper adjusting ring.
- Remove the guide (9) with the upper adjusting ring (8).
- Note the position of the lower adjusting ring (7) (by marking axially on the nozzle (6) and the ring). This will quickly help to find the original position prior to disassembly. Unscrew the lower adjusting ring screw (22) in order to unlock the lower adjusting ring.
- To access the nozzle top surface (6) for maintenance, screw down the lower adjusting ring (7).

8.1.2 PARTIAL DISASSEMBLY (SPRING COMPRESSED)

This should never be practiced for standard maintenance. This procedure is only applicable for fast access to the internal parts of a valve during the commissioning stage (Butt-weld inlet connections only) and only if absolutely essential (at the direction of and under the full responsibility of the operator). It should be ensured that optional part 107-4 have been delivered with the valve or are held by the accredited service authority.

Cap assembly

- Remove the lifting lever (30) taking out the lever pin (27) the pin circlip (87) and the washer (86).
- Remove the fork (29) taking out the fork pin (25) the pin circlip (87) and the washer (86).
- Unscrew the three cap screws (33) from the cap (5) and take out the cap (5).
- Remove the spindle nut (26) by taking out the spindle nut cotter pin (70).

Starsteam superstructure and spring compression locknut

The spring compression bolt (107-4) allows the set pressure to be preserved.

- Screw the spring compression bolt (107-4) on to the spindle (13) until it makes contact with the yoke (3).

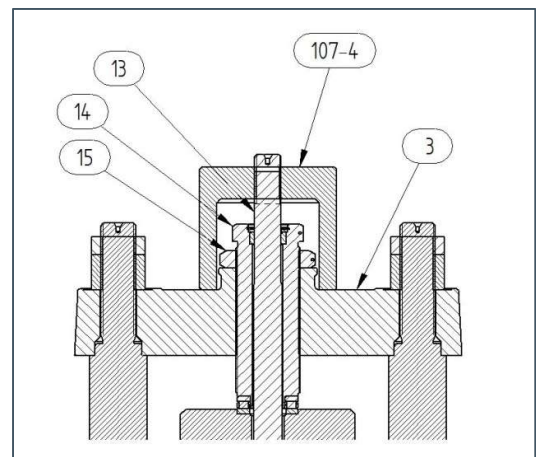

FIGURE 13

Once the spring compression is locked:

- Unscrew and remove the cover nuts (60) in order to release the cover (2).
- Unscrew and remove the 4 studs (35) from the body (1).
- Unscrew the rod nuts (50).
- Carefully take away superstructure from the body (parts are given in table B from section 8.4.1).
- Finally, remove the rods (20) from the body.

Guide and adjusting rings

- Unscrew the upper adjusting ring screw (23) in order to unlock the upper adjusting ring (8).
- Remove the guide (9) and the upper adjusting ring (8).
- Unscrew the lower adjusting ring screw (22) in order to unlock the lower adjusting ring (7).
- To access the nozzle top surface (6) for maintenance, screw down the lower adjusting ring (7). To prepare the body (1) for welding of the inlet connection then screw upwards and take the ring (7) off the nozzle (6).

8.2 INSPECTION

This step should be considered as a vital function in the maintenance operation. Each component should be inspected for detection of any corrosion, galling, sticking or any other possible material damage.

8.2.1 DISC

The disc (11) must be free of erosion or steam cutting. The disc seat dimensions and tolerances must be checked by using a suitable measuring instrument (see [section 8.3.1](#)). The disc should never be machined. If the disc seat has been subject to damage which is considered to be slight, then proceed in accordance with the seat lapping instructions observing the tolerance allowances.

8.2.2 NOZZLE

The nozzle (6) must be free of erosion or steam cutting particularly on its seat face. The nozzle seat dimensions and tolerances must be checked (see [section 8.3.2](#)).

8.2.3 DISC-HOLDER

The holes at the bottom of the disc-holder (56) must remain open.

8.2.4 SLIDING RING ASSEMBLIES

The sliding rings (12) are made from two segments. The ends of the segments are cut at 45°. Should a segment be broken, the entire sliding ring assembly must be replaced.

The outer diameter of the segments should not be less than the following tolerances, in order to maintain the clearance between the disc-holder and the guide.

Orifice	Type #	Outer diameter (mm)	Tolerances (mm)
1	STH12-01	60	-0.076
2	STK12-01	76	
3	STL12-01	100	-0.090
4	STM12-01	116	
5	STN12-01	134	-0.106
6	STP12-01	154.5	
Q	STQ12-01	193	-0.122
R	STR12-01	232	
RR	STS12-01	255	-0.137
T	STT12-01	305	

TABLE 6

8.2.5 GUIDE

No specific control needs to be carried out due to there being no metal gliding surfaces. Any noticeable galling would indicate that the sliding rings (12) should be replaced as the thickness would be out of the mandatory tolerance bands and would allow the disc-holder (56) to be in contact with the guide (9).

8.2.6 OVERLAP RING

The outside diameter of the overlap ring (28) should not show any marks (galling, pitting, etc.). The threads should not show any damage.

8.2.7 FLOATING WASHERS

Before disassembly of the cover assembly, the floating washers (18) should be checked to ensure freedom of movement. After disassembly, the floating washers must not show any sign of deformation.

8.2.8 COVER PLATE

There should be no restriction in the vent hole.

8.2.9 SPINDLE RING

If the spindle ring (93) is broken or damaged, it must be replaced.

The inner diameter of the ring should not be less than the following tolerances, in order to maintain the clearance in between the spindle (13) and the set screw (14).

Orifice	Type #	Inner diameter (mm)	Tolerances (mm)
1	STH93-01	16	+ 0.027
2	STK93-01	20	+ 0.033
3	STL93-01	22	
4 5	STM93-01	27	
6	STP93-01	33	+ 0.039
Q R RR	STQ93-01	39	+ 0.039
T	STT93-01	48	+ 0.039

TABLE 7

8.3 LAPPING

After a period of operation, when at which point relief safety valve might naturally start to leak, it should be reconditioned by performing lapping operations on the seat surfaces of the nozzle and the disc, either manually by machine, to ensure that good tightness, plus opening and closing phases are restored.

This operation requires specific skills and experience and may be carried out only by qualified personnel.

If such essential skills are not available, the valve should be returned to Trillium Sarasin-RSBD or one of its identified accredited partners to be reconditioned (Your nearest Trillium representative should be contacted in such an occurrence).

8.3.1 DISC

The disc should never be lapped directly on to the nozzle. Before lapping, check that parts are not damaged or pitted in any way which could result in damage to the lapping set tool or could leave traces after the operation has been completed. Any distorted surfaces which are found as a result of this procedure not being followed must be re-machined on a lathe.

Trillium recommends the use of LAMPLAN lapping rods MM – shape A – for the disc (please contact Trillium in order to acquire this tool). The lapping rods are drilled so as to allow the disc seating surface to be in contact with the lapping surfaces.

Lapping is done in two steps:- (a) gross lapping (b) finishing. Trillium recommends the use of the following LAMPLAN diamond pastes (table 8):

Lapping step	Type	µm	Reference
Gross Lapping	6 213	6	01 06213 00
Polishing	3 213	3	01 03213 00

TABLE 8

Spread a thin coat of the gross lapping paste on to the lapping rod surface and place the disc on to the top of the lapping rod. Do not apply hand pressure; the weight of the disc will be sufficient.

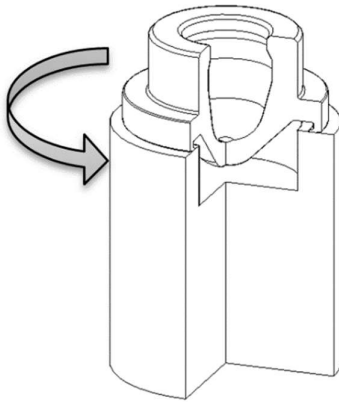

FIGURE 14

Rotate the disc on the lapping rod. Lift the disc periodically to check the seat surface (figure 14). Apply further coats of the paste to the lapping tool and repeat the operation until all defects have been removed. The entire contact surface must have an identical texture and appearance, with no trace of scoring.

Clean the contact surfaces of the lapping set and disc, using solvent.

For finishing, spread a thin coat of the polishing paste on to the lapping set. Proceed as before for around ten minutes. If the contact surface does not appear fully polished, repeat the operation but without using any more paste, however, simply spread the remaining paste evenly, using only a finger.

The lapping process is complete when the entire contact surface has no marks and is uniformly mirror polished.

Carefully clean the contact surface, using solvent and a very clean soft white cloth, until any traces of impurity have been removed.

Proceed in the same way to recondition the lapping tools and the lapping rod surface

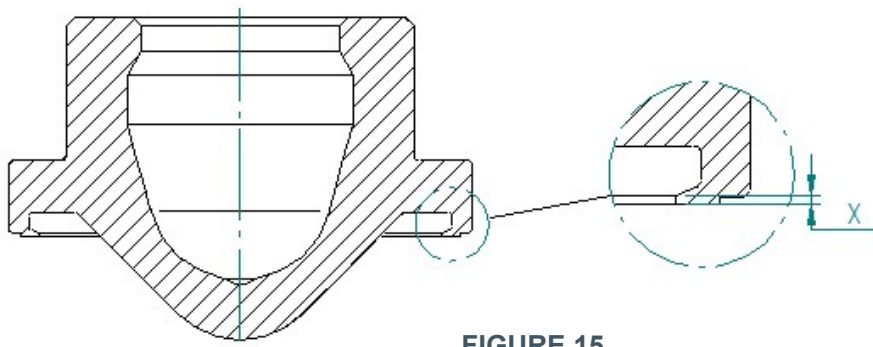

FIGURE 15

The disc seat maximum repair (figure 15): X dimension must not go below 0.1 mm for all orifices. If the repair dimension is out of the tolerance, the disc must be replaced.

8.3.2 NOZZLE

Trillium recommends the use of LAMPLAN lapping rods MM – shape B – for the nozzle (please contact Trillium in order to acquire this tool). The polishing lapping step only needs to be performed (as outlined in section 8.3.1). It is recommended that the same paste is used as referenced in section 8.3.1

For any valves with flanged inlet connections which might be returned to a Trillium accredited workshop, place the inlet flange should be placed rigidly on a flat and horizontal surface.

Spread a thin coat of finishing paste on the lapping rod surface and proceed in the same way as for the disc (figure 9).

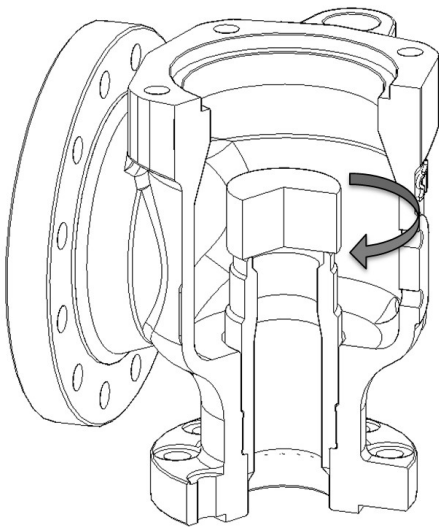

FIGURE 16

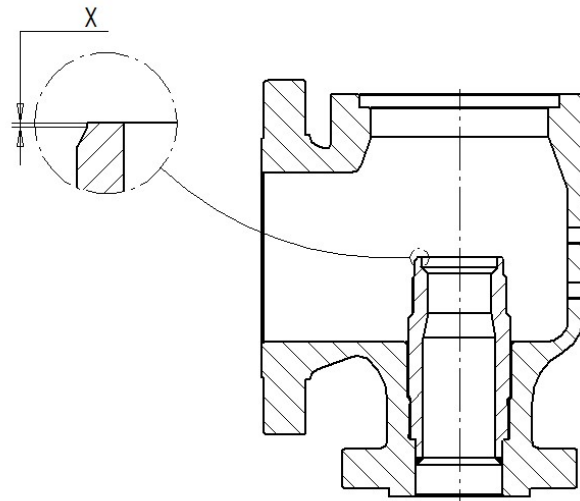

FIGURE 17

The nozzle seat maximum repair (figure 10): the dimension X must not go outside the tolerance limit of 0.1 mm for all orifices. If the nozzle at any time falls outside this parameter, it should be either exchanged with an identical part which has been supplied by Trillium or it should be suitably machined to re-establish the initial X dimension (table 9), without exceeding the H dimension (table 9).

Orifice	X init. ±0.1 (mm)	H max (mm)
1	0.5	74.6
2		88.3
3		136.6
4		137.6
5	0.75	155.0
6	1	157.6
Q	1.5	184.5
R		218.5
RR		218.3
T	2	240.0

TABLE 9

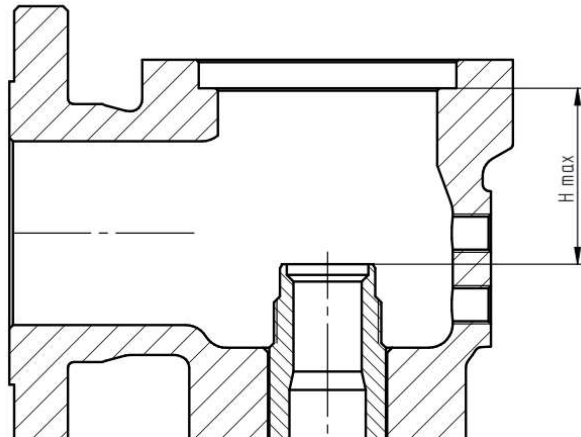

FIGURE 18

If the nozzle needs at any time to be changed, it is recommended that the entire body assembly is changed.

8.4 RE-ASSEMBLY (FULLY DISSASSEMBLED VALVE)

8.4.1 LOWER PART

- Screw the lower adjusting ring (7) on to the nozzle (6). Adjust in direct accordance with the mark which was made and the notes which were taken during the disassembly stage. The edge of the lower adjusting ring should be below the nozzle seat (6).
- Screw in the lower adjusting ring screw (22).
- Adjust the lower adjusting screw so that the pin is engaged between 2 notches. The lower adjusting ring screw should prevent the lower adjusting ring (7) from turning but should not rest on it. The ring must be able to have slight movement in between the two notches. This procedure and the action should be checked manually.
- For any final standard adjustment should it be necessary, please refer to section 8.4.7.4.
- Screw the upper adjusting ring (8) on to the guide (9). Adjust in direct accordance with the mark which was made and notes which were taken during the disassembly stage. The lower face of the adjusting ring should be aligned with the face of the disc holder (56) as first initial adjustment if no mark has been taken..
- Insert the guide assembly (8+9) into the body (1).
- Screw the upper adjusting ring screw (23) following the same procedure as the lower adjusting ring screw (22).

8.4.2 YOKE ASSEMBLY PREPARATION

- Prepare the yoke assembly parts: the yoke (3), set screw (14), set screw nut (15), spindle ring (93), set screw washer (94) and set screw circlips (95).
- Insert first the spindle ring (93) into the set screw (14), then the set screw washer (94) and finally the set screw circlip (95).
- Screw the set screw nut (15) on to the set screw (14).
- Screw the assembled parts on to the yoke (3) by its upper side.

8.4.3 COVER ASSEMBLY PREPARATION

- Prepare the cover assembly: the cover (2), floating washers (18), two spacers (92), floating washer retainer plate (17) and four retainer plate screws (91).
- Insert the lower floating washer (18) into the cover with its bevelled face in the upwards position.
- Insert the spacer (92) with one hole facing the exhaust hole of the cover (2).
- Insert the upper floating washer (18) into the cover with its bevelled face in the downwards position.
- The upper side of the floating washer must be slightly below the level of the retaining plate.
- Hold the floating washer retainer plate (17) in place and tighten the four screws (91).
- Check that the floating washers (18) are horizontally motion free.

8.4.4 SPINDLE ASSEMBLY PREPARATION

Prepare the following three assemblies:

- Spindle (13), disc nut (16), lift stop (10) and overlap ring (28) ;
- Disc holder (56), two sliding rings (12) and disc (11) ;
- Cotter pins (88), (89) and (90).

Internal assembly of the spindle:

- Insert the disc nut (16) from the lower side of the spindle (13). The surface of the sphere should not be marked in any way. Screw the disc nut up to the first pin hole which is positioned in the downside of the notch.
- Return the spindle with the sphere facing upwards. Assemble the disc (11) and the disc holder (56) on to the spindle (13) from the lower side of the spindle. The disc should be turned manually until it comes to a mechanical stop, ie, it makes contact on the spindle sphere inside the disc.
- Manually push on the disc sphere (11) in order to maintain the contact with the spindle sphere (13). Screw the disc nut until contact is made with the disc-holder (56). Then, maintaining the disc (11) contact with the spindle (13), check that there is no clearance between the disc (11) and the disc holder (56). Unscrew the entire assembly and adjust the disc nut (16).
- Once there is no clearance, take off the assembly disc (11) / disc holder (56).
- Unscrew the disc nut (16) by ¼ turn.
- Insert and open the cotter pin (88).
- Reassemble the disc (11) and the disc holder (56). The disc should be able to hinge. This is important to insure a correct reseating and tightness levels.
- Insert the lift stop (10) via the top of the spindle (13) and screw it down until the second pin hole is slightly above the disc holder. For the correct positioning, please refer to section 8.4.6.
- Insert the overlap ring (28) via the top of the spindle (13) and screw it down by a few thread steps (this is a temporary position – keep the overlap ring on the top of the thread at this stage).
- Assemble the sliding segments (12) around the disc holder.

8.4.5 PREPARATION OF LIFT ADJUSTMENT MECHANICAL STOP SETTING

- Insert the spindle assembly (13) into the guide (9). The pin holes should be positioned facing towards the outlet flange.
- Insert the two rods (20) into the external body lugs (1).
- Centre the spindle (13) by assembling the pre-assembled yoke (3) over the top of the spindle.

8.4.6 ADJUSTMENT OF THE LIFT

The full lift settings are given in the following table 13:

Inlet (inch)	Outlet (inch)	Orifice designation	Orifice Diameter (mm)	ASME certified		Non ASME certified	Tolerance on lift (mm)
				Full lift (mm)	Min. restricted lift (mm)		
1.5	3-4	1	28.6	7.2	4.0	2.2	+0.4 / -0
2	3-4	2	37	9.3	5.2	2.8	+0.5 / -0
2.5	6	3	47.6	11.9	6.6	3.6	+0.6 / -0
3	6	4	57.2	14.3	7.9	4.3	+0.7 / -0
4	3-4	5	66	16.5	9.1	5.0	+0.8 / -0
4	6	6	76.2	19.1	10.6	5.8	+1 / -0
6	8	Q	95.3	23.9	13.2	7.2	+1.2 / -0
6	10	R	114.3	28.6	15.8	8.6	+1.4 / -0
6	10	RR	125.9	31.5	N/A	9.5	+1.6 / -0
8	2 x 10	T	150	37.5	20.7	11.3	+1.9 / -0

TABLE 13

IMPORTANT: The lift dimension is measured between the upper surface of the lift stop (10) and the guide upper surface using a depth gauge. For valves with restricted lifts, the actual lift will be the value which is stamped on the nameplate and in the computerized sizing report.

- Adjust the lift stop (10) with one hand whilst with the other hand prevent the spindle from turning thus stopping the disc (11) from turning on the seat.
- To lock, screw down the lift stop in order the first notch faces the pin hole.
- Insert and open the cotter pin (89). The cotter pin "head" must be in the horizontal position to ensure that the end of the pin will not touch the cover whilst the spindle being subjected to lift.
- Screw down the overlap ring (28) so that the external grooves are slightly below the level of the pin hole.
- Take off the yoke assembly (3)
- Screw down the four cover studs (35) using nominal torque
- Assemble the cover (2) on the body (1) by inserting from the top of the spindle (13).
- Tighten the cover nuts (60) using nominal torque on to the cover studs.

8.4.7 UPPER PART

- Prepare the upper parts: the ball thrust bearing (104), spring (46) and spring washers (45; 47).

8.4.7.1 Spring assembly

- Grease the hinge surface, (ie, the spindle contact area of the lower spring washer (45) and mount it in place on the spindle (13). Make sure the hinge area is in the down position.
- Put the spring (46) in place above its lower washer (45).
- Grease the bearing bore of the upper spring washer
- Grease all the parts of the ball thrust bearing (104).
- Insert the thrust bearing (104) into bore of the upper spring washer (47) and chamfer up.
- Insert the upper spring washer on to the spring, with the bearing in the upwards position.
- Put the yoke assembly (3) on to the rods (20).
- Screw and tighten the nuts (50) on to the lower and upper side of rods (20).
- Screw down the set screw to ensure contact with the thrust bearing (104) of the upper spring washer (47), and then tighten the screw again by approximately 3 turns. This procedure is to maintain the correct position of each part.

8.4.7.2 Adjustment of overlap ring

- Screw down the overlap ring (28) until contact is made with the lift stop (10).
- Screw up the overlap ring by the number of turns shown in the following table (14):

Orifice	Pitch on the stem (mm)	Recommended number of turns after contact with the lift stop
1	1	5.5
2	1	6.0
3	1.5	5
4	1.5	5.5
5	2	4.5
6	2	4.5
Q	2	5.75
R	2	7.25
RR	2	7.25
T	2	7.5

TABLE 14

- Once the overlap ring (28) has been adjusted, adjusted, screw the overlap ring (28) it should be moved up by 1/8 turn maximum until the pin hole is facing a slot.
- Use the cotter pin in the unopened position (90) to block the overlap ring. The end of the cotter pin will be opened at a later stage when sealing the valve.

8.4.7.3 ASSEMBLY OF CAP

- Prepare the cap assembly parts: the spindle nut (26), cap (5), fork (29), long length fork pin (25) small length lever pin (27), lever (30), spindle nut cotter pin (70), three cap screws (33), four pin circlips (86) and four pin washers (87)
- Screw down the spindle nut (26) on to the spindle (13). The pin hole must be aligned with a slot.
- Insert the unopened spindle nut cotter pin (70). The pin head must be in the horizontal position. The ends of the cotter pin will be opened at a later stage when sealing the valve.
- Pre-position the 3 cap screws (33) on to the cap (5) without any of the cap screw ends overtaking protruding inside the cap.
- Assemble the cap on to the yoke so that the lifting lever (30) is at the opposite side of to the outlet flange.
- Manually screw the three cap screws in order to centre the spindle nut in the cap. The spindle nut must not be in contact with the cap.
- Finish the tightening the cap screws with a screw driver.
- Assemble the lifting lever (30) into the correct position along with the small lever pin (27) and pin both parts together. To lock it, use two pin washers and two circlips, one circlip for each end of the axis.
- Assemble the fork (29) into the correct position and along with the long fork pin (25) (long) and pin all parts together. Use two pin washers and two circlips, one circlip for each end of the axis, in order to lock it.

8.4.7.4 ADJUSTMENT OF THE LOWER ADJUSTING RING

- Take off the lower adjusting ring screw (22).
- Raise the lower adjusting ring until it is in contact with the disc holder (56). Do not apply any effort so that compressing compression of the spring may be avoided.
- Then, lower the ring by the number of notches shown in the table below:

Orifice designation	Lower Adjusting Ring (quantity of notches)
1	3
2	5
3	8
4	12
5	13
6	17
Q	25
R	20
RR	25
T	28

TABLE 15

- Move the lower adjusting ring screw (22) again checking that the pin is between 2 notches. It must prevent the lower adjusting ring (7) from turning but it must not rest on it. The ring must be able to move slightly in between the two notches in a hinged motion. The fitting and the motion should be checked manually.

8.4.7.5 ADJUSTMENT OF THE UPPER ADJUSTING RING

The standard adjustment details for the upper adjusting ring are given in the paragraph 8.4.1. The lower face of the adjusting ring should be aligned with the face of the disc holder (56) as first initial adjustment if no mark has been taken..

Should any 'fine' adjustment of the upper adjusting ring be necessary whereby the blowdown setting should need more accuracy. The additional procedures which are shown below should be observed. The upper adjusting ring may be adjusted only if the adjustments of the overlap ring and the lower adjusting ring prove to be unsatisfactory. Our experience shows that the only necessary adjustment of the upper adjusting ring is on low pressure applications. Its position should not be changed before the correct blowdown has been attempted by changing the position of the overlap ring and the lower adjusting ring.

If 'fine' adjustment is to be considered then proceed as follows:

- To reduce blowdown the upper adjusting ring shall be raised.
- To increase blowdown the upper adjusting ring shall be lowered.

The upper adjusting ring shall be turned by a quarter turn at each adjustment depending on the existing blowdown.

9 TESTING

9.1 HYDROSTATIC TEST

It is possible to use various methods to perform hydrostatic tests as outlined below.

Important note: Hydrostatic tests should be performed at no greater than 1.5 times the set pressure of the safety valve.

9.1.1 FLANGED INLET END

The hydrostatic tests of the boiler unit are recommended to be performed without the safety valve being installed. This would prevent damage to the valve during the tests. A blind flange should be used to blank off the boiler opening where the safety valve will be connected.

If a test gag is being used, the test pressure may be 1.5 the boiler maximum allowable working pressure. The procedure for using a test gag is defined in section 9.1.4.

9.1.2 BUTT-WELD INLET END

A hydrostatic test plug should be used for safety valves which have butt-weld inlet connections in order to perform hydrostatic testing of the boiler.

Where a hydro plug is used, the test pressure must be no greater than 1.5 times the set pressure. The procedure for using a hydro plug is defined in section 9.1.3

Where a test gag is used, the test pressure must be no greater than 1.5 times the set pressure. The procedure for using a test gag is defined in section 9.1.4.

9.1.3 TEST GAG

The gag for hydrostatic testing may be used for both: flange and butt-weld inlet connections.

To assemble the test gag, the cap needs to be removed from the valve. Please refer to section 8.1 for cap removal instructions. Position the test gag caliper and the gag screw as per the following drawing:

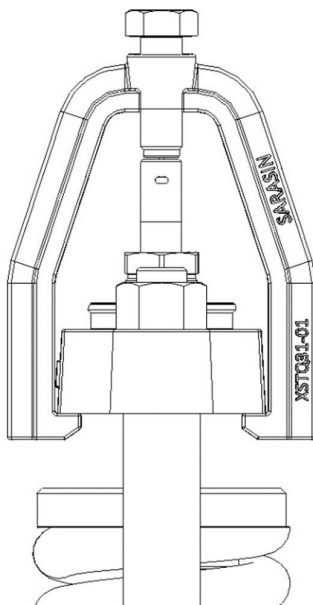

FIGURE 22



- Make sure that both legs of the caliper are vertical and in line with the spindle axis.
- When the caliper is correctly positioned, screw the gag so that it is in contact with the spindle.

Before tightening the test gag, the system pressure should be increased to 80% of the set pressure (use the lower set pressure of all safety valves which might be installed on the system). Then, apply a light torque to lock the gag into place (a high torque could result in damage to the disc and nozzle seats).

If any leakage occurs, the system pressure needs to be lowered so that the gag may be lightly retightened. The gag should not be retightened without the system pressure being lowered, as damage to the seating surfaces could occur.

After completing the hydrostatic tests, the pressure shall be decreased to 90% of the lowest set pressure before the test gag is removed from the valve. At 90%, the disc lip will not be subject to damage during test gag removal. The cap may then be mounted back on the valve. At this point, the test pressure may be turned off.

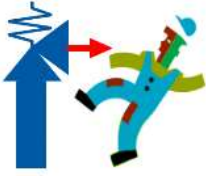
9.2 SET PRESSURE AND ADJUSTMENT OF RINGS

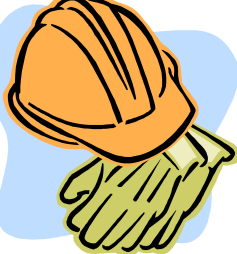
DANGER	WARNING	CAUTION	CAUTION
			
<p>Never face the outlet of a valve when it is discharging as this may result in serious personal injury or death.</p>	<p>Always take off the test gag before performing the pop test. Replace the gag before adjusting the screw and the rings to prevent any unexpected valve opening.</p>	<p>Protect against high noise levels which occur during popping tests. Keep a safe distance when the test is being performed.</p>	<p>Helmets and gloves must be worn to prevent any injuries while operating or working on the valve.</p>

All the safety valve are tested at the Trillium factory. Nevertheless, a calibration on the actual equipment with a full capacity is recommended. This will ensure a proper opening and the perfect rings adjustment.

The factory adjustments are initial ones only. Final adjustments on the operating system shall be always preferred, especially if particular blowdown are required.

The safety valve set pressure may be checked by using either of the following procedures –

- 1 The system pressure increase
 - 2 An online testing device.
- Using the first method, the system pressure is increased until the popping point of the safety valves is reached. This method allows both verification of the set pressure and clarification of the blowdown.
 - For the second method, the Trillium online testing device is used to determine the valve's opening pressure at the normal system operating pressure. The difference between set pressure and operating pressure which is necessary to test the valve is compensated by the online testing device. This online testing device is made up of a hydraulic cylinder and pressure, temperature and force transducers which are able to open the valve and to give precise values of the force needed to perform this procedure (see also section 9.3)

Before the set pressure test is performed, the following procedures must be followed:

- Please follow the recommendations for installation which are provided in section 7,
- The pressure gauge which is used to check the opening pressure shall be as close as possible of the valve inlet;
- The test gag must have been removed prior to performing the test. Should any adjustment be necessary, the valve should be gaged to make sure it remains closed.

9.2.1 SET PRESSURE ADJUSTMENT

NOTE : For insitu intervention, make sure the operating pressure is decreased as such to prevent the valve top open during the adjustments.

In order to change or adjust the set pressure, cap assembly should be removed as per the instructions which are provided within section 8.1.

To adjust the set pressure, note number of complete turns and mark on the screw and the yoke to quickly locate the correct zone of spring compression as shown in section 8.1.1 (paragraph “spring assembly”).

To change or adjust the set pressure, unscrew the set screw locknut (15).

- To increase the set pressure, screw the set screw downwards.
- To decrease the set pressure, screw the set screw upwards.

The set pressure adjustment must not be above ± 5 % of the original nameplate set pressure. Any adjustment beyond this limit, please consult Trillium so that we may check the possibility.

Once the adjustment is acceptable, screw the locknut (15) into place.

9.2.2 BLOWDOWN

NOTE : For insitu intervention, make sure to gag the valve to prevent the disc to relief during the rings adjustment. Otherwise the tools used for the adjustments could make the disc to open by accident. This does not prevent the system pressure to rise and expose all the intervening personal near the valve.

To obtain a short blowdown (high closing pressure), the overlap ring (28) shall be lowered. For this purpose, remove the overlap ring pin (90) and screw down the overlap ring by one notch. If the valve starts to chatter, cease moving the overlap ring. Leave the overlap ring at the most recent position where the valve was free from chatter. Start to move the lower adjusting ring down. If this still does not provide satisfactory results, move the upper adjusting ring up as described in section 8.4.7.4.

To obtain a long blowdown, the steps should be the same but following the opposite direction for the rings: Move the overlap ring upwards. If this does not provide satisfactory results, move the lower adjusting ring upwards. If it is found to be essential, move the upper adjusting ring downwards.

The blowdown should always be as long as possible based upon the operating conditions. Short blowdown ranges may lead to chattering.

9.2.3 UPPER AND LOWER RINGS ADJUSTMENT

Initial adjustments should be kept unless required as the above description..

Please refer to section 8.4.2 for standard ring adjustment if required.

In case of any issues with set pressure adjustment, please contact Trillium aftersales department.

9.3 CALIBRATION CHECK WITH ONLINE TESTING DEVICE

It is sometimes required to check for the calibration of the valve at the commissioning stage or periodically. Such activity can be achieved using a specific online testing electronic device. Trillium can arrange to perform such activity.

The use of such a method instead of the lifting of the disc under operating pressure allows to prevent certain risks such a valve seat damages, superheater tube damages. It allows to eliminate high costs from feed water, fuel, and minimise the personal costs.

Only the opening pressure can be verified with this method. If required the blowdown adjustments are achieve on live steam flow.

9.4 VALVE SEALING



Once the valve is correctly adjusted and all the tests have passed succesfully, it is necessary to seal the valve in compliance with most of the international regulations. This prevents changing the adjustments. It allows also to identify the last intervening organisation (manufacturer, service centre or end-user) that will be responsible for the last adjustments.

The V series (Starsteam™) safety valve includes means to allow the seal of all the adjustments.

In case a seal is broken, please make sure to inform your inspection department and arrange a valve inspection as quick as possible.

Also, once the seal is broken, the valve will not be covered anymore by the warranty.

10 MAINTENANCE TOOLS

- Disc lapping tool

Orifice	Trillium reference	
	Lapping tool	Tool kit
1	9195D019	9195D024
2	9195D020	9195D025
3	9195D029	9195D026
4	9195D021	9195D027
5	9195D022	9195D028
6	9195D030	9195D033
Q	9195D031	9195D034
R	9195D023	9195D035
RR	9195D032	9195D036
T	Disc too large for hand lapping – new disc order recommended	

TABLE 16

Note : the tool kit includes the lapping tool, the Lamplan diamond paste 6.213(10g), 1 liter fluid MM712, 1 red spray vessel 0.5L (empty)

- LAMPLAN diamond paste 6.213 (syringue) – 10g – Trillium ref 9195D011
- 1 liter fluid MM712 – Trillium ref 9195D017
- 1 red spray vessel 0.5L (empty) - Trillium ref 9195D018
- Lifting eyes
- Synthtic slings

11 TROUBLESHOOTING

PROBLEM	POSSIBLE CAUSE	CORRECTIVE ACTION
The disc does not move (no lift)	Test gag still in place	Remove the test gag
	Foreign material trapped in between a moving part and fixed one.	Carry out maintenance to remove the part and to overhaul the potential damaged parts.
The disc does not go to the full rated lift	Upper adjusting ring too high.	Adjust the position of the ring.
	Overlap ring too low.	Adjust the position of the ring.
Simmer	Lower adjusting ring too low.	Adjust the position of the ring.
	Steam line / equipment vibrations	Investigate the source of the vibration and strengthen the support.
Seat leakage	Damaged seat	Carry out maintenance to lap or to change the disc and to lap or to machine the nozzle.
	Part misalignment	Inspect the contact surfaces of each component from the set screw to the disc. Check also the spindle alignment and concentricity.
	Disc hinge is not has insufficient articulation	Inspect the disc and spindle hinge surface.
	Incorrect discharge piping support allowances or its weight supported by the valve outlet flange.	A Rearrange the support hardware. Install if drip pan if necessary. Review the outlet piping installation.
The disc does not reseat	Lower adjusting ring too high.	Adjust the position of the ring.
	Foreign material	Carry out maintenance to remove the component and overhaul any damaged parts.
Long blowdown	Upper adjusting ring too low.	Adjust the position of the ring.
	Built-up back pressure too high.	Identify the source of the high back pressure. Decide by a process of elimination the source and extent of the problem – reassess, review and reconstruct the outlet piping accordingly.
	Overlap ring too high.	Adjust the position of the ring.
Chatter or short blowdown	Upper adjusting ring far too high.	Adjust the position of the ring.
	Overlap ring far too high.	Adjust the position of the ring.
	Upstream pressure drop too high.	Redesign the inlet piping to reduce the pressure drop to less than the ½ blowdown value

12 SPARE PARTS

After prolonged and intensive use or in exceptional working conditions, a safety valve will need to be serviced or overhauled.

Such work must be carried out by a skilled technician. The Trillium Group offers training and education programmes to cover all areas of maintenance and repair. Please consult your nearest Trillium representative for more details.

To perform basic maintenance tasks within the shortest possible timeframe, it is recommended that class “A” spare parts are purchased at the same time as new valves.

Spare parts predictability	
Parts classification	Replacement frequency
A	Most frequent
B	Less frequent but critical
C	Seldom
D	Hardware
E	Practically never replaced

TABLE 17

Parts classification can be found in section 6.2 (table 2).

It is necessary to indicate the serial number which is stamped on the valve nameplate in order to guarantee the authenticity and the interchangeability of spare parts.

13 DISMANTLING

The user must make sure that the product is disposed of in an appropriate manner, according to the regulations in force in the country where the machine is installed, thus avoiding a negative impact on the environment and human health.

14 GENUINE PARTS

The use of spare parts which are not obtained from a genuine Trillium source or a Trillium accredited company exposes product, plant and personnel to high risk.

- Sarasin-RSBD™ parts only are designed and produced to be used in Sarasin-RSBD™ valve designs.
- Sarasin-RSBD™ parts carry warranties.
- Trillium has an global aftersales network (sales offices, distributors and agents) to respond immediately to requests
- For any products which may be considered obsolete, Sarasin-RSBD™ parts may still be produced on demand.

If you are not aware of your nearest representative, please contact the manufacturing operation at the address shown below:

Trillium Flow Technologies France

Rue Jean-Baptiste Grison – ZI du Bois Rigault

62880 Vendin-le-Vieil - France

Tel: +33 3 21 79 54 50

Fax: +33 3 21 28 62 00

Aftersales department:

WVCFR.aftersalessarasinrsbd@trilliumflow.com

Service :

aftermarket.sarasinrsbd@trilliumflow.com

Sales :

sales.sarasinrsbd@trilliumflow.com

15 CODIFICATION

1 2 3 4 - 5 - 6 - 7 / 8 - 9

VF 36 4 3 32 A M TV 1

1 V: Starsteam™

- Semi nozzle safety valve
- Stardisc™
- Dual Adjusting Ring
- Thermoglide™ rings

VF: Flanged inlet

VW: Buttweld inlet

2 Inlet x Outlet

- 2 : 2" (DN50)
- 3 : 3" (DN80)
- 4 : 4" (DN100)
- 5 : 2.5" (DN65)
- 6 : 6" (DN150)
- 7 : 1.5" (DN40)
- 8 : 8" (DN200)
- 9 : 10" (DN250)

3 Orifice Designation

- 1 – 2 – 3 – 4 – 5 – 6 – Q – R – RR – T

4 Valve Rating (ASME)

- 3 : 600#
- 4 : 900#
- 5 : 1500#
- 6 : 2500#
- 7 : 3000# (BW only)
- 8 : 4500# (BW only)

5 Material of construction (body)

- 30 : SA 216 Grade WCC
- 32 : SA 217 Grade WC6
- 42 : SA 217 Grade WC9
- 52 : SA 217 Grade C12A
- 16 : SA 351 Grade CF8M
- Z : other material

6 Flange Type

- A : ASME B16.5 and EN 1759-1
- P : EN 1092.1 (whatever possible size to drill)
- Z : Other

7 Flange Finish Type (inlet)

- M RF Smooth finish
- J Ring Tool Joint
- E2 Small male face
- E1 Large male face
- E Male face
- F2 Small female face
- F1 Large female face
- F Female face
- C2 Small tongue face
- C1 Large tongue face
- C Tongue face
- D2 Small groove face
- D1 Large groove face
- D Groove face
- Z Other flange finish (including outlet)

8 Option

- A No option
- P Hydrotest plug
- Q Non-copper content
- R Restricted Lift
- S Weathershield
- T V stamp
- U UV stamp
- V Test gag
- V1 Spring compression nut
- W Outlet flange 300#
- Z Special
- Z1 Government Ring

9 Interchangeability

- 1

SARASIN-RSBD and STARSTEAM are trademarks and/or registered trademarks of Trillium Flow Technologies France SAS; TRILLIUM is a trademark and/or registered trademark of Trillium Engineering Services Limited.