

**Begemann®**

**Gabbioneta Pumps™**

Vertical In-line Single Stage Pumps

**BSD Range**

## General information

The BSD range heavy duty process pumps are vertical in-line overhung pumps with single suction impeller designed for full compliance with latest edition of API 610 and BS4082 Class R Standards.

## Main design features:

- Pump components geometry optimised through hydraulic, structural, thermal and dynamic f.e.m. analysis to guarantee high product reliability.
- In-line arrangement for suction and discharge nozzles integrally cast with the casing.
- Closed type impeller with front and rear wear rings as well as balancing holes, to minimize the axial thrust.
- Large eye suction impeller to meet low NPSH requirements.
- Back pull-out construction for easy maintenance procedures.
- Stiff shaft design. Rotor operates below 1st critical speed.
- Rotor axial thrust supported by a duplex oil lubricated ball angular contact type bearing as standard.
- Deep stuffing boxes, designed in accordance to API 682 Standard, suitable to accept any type of mechanical or packing seal.
- Labyrinths and deflectors at both bearing housing ends to maximize protection against dirt.
- A wide range of sizes and material combinations complete the variety of the offered product.

## Options

The following pump designs can be provided:

- Heavy duty bearing housing for high suction pressure applications
- Anti reverse rotation device
- Air fan cooling system provided on bearing bracket and/ or mechanical seal when required by hot temperature applications
- Special bearing isolators at both bearing housing ends
- Grease lubrication
- Oil mist lubrication (pure or purge)
- Temperature and/or vibration detection and monitoring equipment

## Main pumps applications refer to heavy duties on

- Oil & Gas
- Offshore platforms and FPSO vessels
- Refineries
- Petrochemical and chemical plants
- Feedwater and power plant auxiliaries

## Operating data

### Capacity

up to 500 m<sup>3</sup>/h (2201 Gpm)

### Head

up to 300 m (984 feet)

### Temperature

from - 100°C (-150°F) to 400°C (750°F)

### Design working pressure

up to 100 barg (1400 psig)

### Rotational speed

up to 3600 rpm

## BSD vertical in-line operating range

### Family curves 3000 rpm

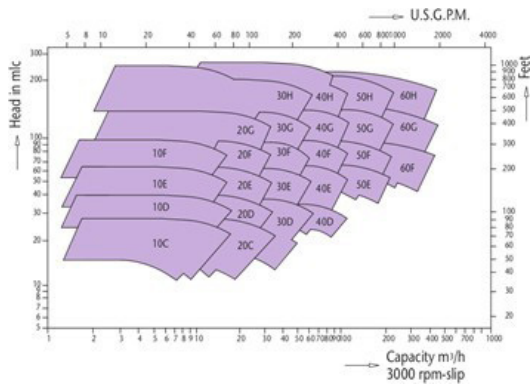

### Family curves 3600 rpm

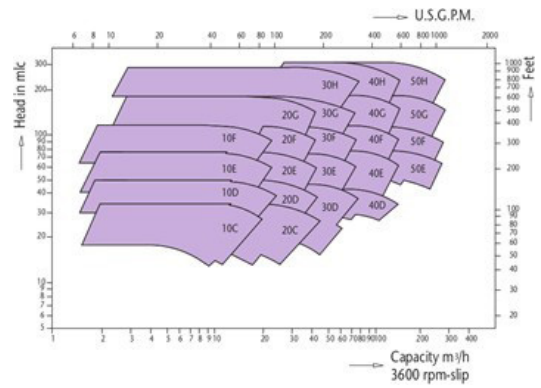

### Family curves 1500 rpm

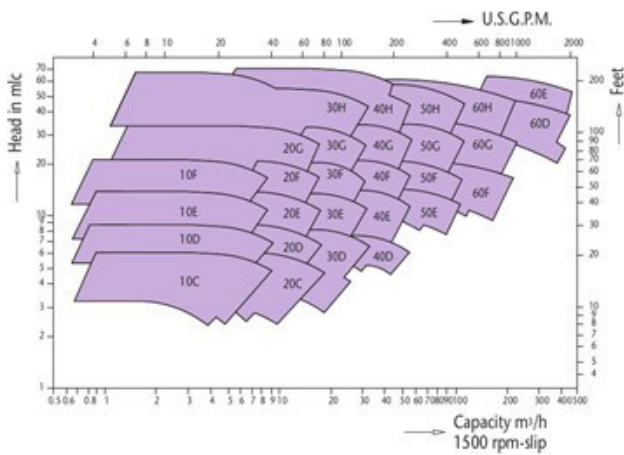

### Family curves 18 rpm

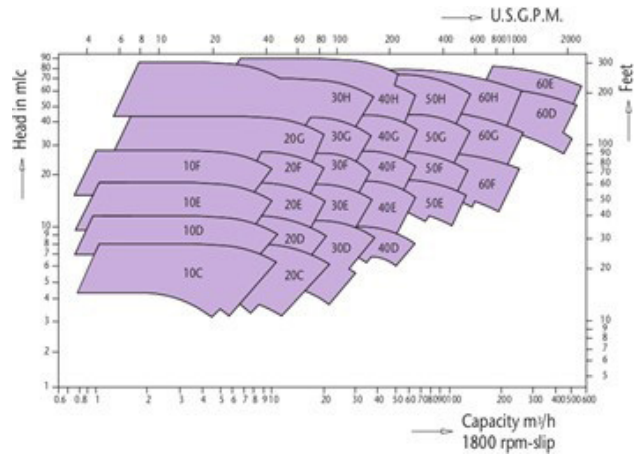

## Overall dimensions

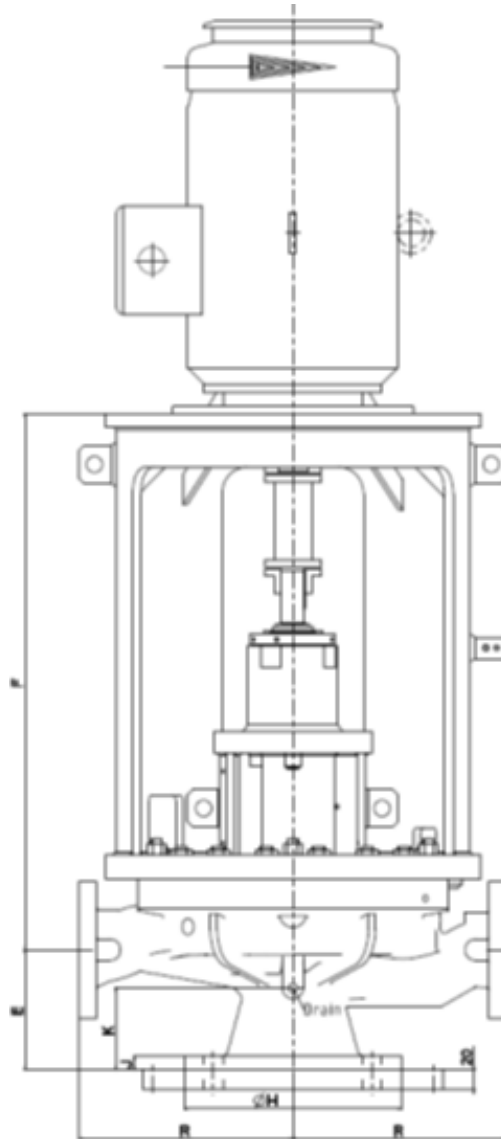

PUMP TYPE	NOZZLE SIZE	E mm	H mm	J mm	K mm	DRAIN SIZE	R mm
BSD R10E-I	1.5"/1.5"	125	265	20	70	3/4"	265
BSD R20C-I	2"/2"	125	335	25	83	3/4"	212
BSD R40G-I	4"/4"	224	405	25	153	3/4"	400
BSD R40H-I	4"/4"	224	405	25	145	3/4"	400
BSD R50F-I	6"/6"	250	405	25	80	1"	355
BSD R60D-I	8"/8"	300	465	30	170	1"	530

## General notes

1. All dimensions are in mm. Do not use for construction unless certified.
2. Dimension F depending on operating conditions

## A century of experience

Since the foundation of the company in 1897, Gabbioneta pumps™ has been engaged in design and manufacture of high quality centrifugal pumps.

The products and the markets served progressively changed from water to chemical industry and finally, in the last thirty years, to API 610 heavy duty pumps for refinery and petrochemical industries.

Product development is based on a thorough interchange of marketing and operating experience within the company and in close cooperation with project and plant engineers.

Manufacturing is carried out in a factory equipped with several modern CNC machines and machine tools. Special note has to be given to the machining centers where pump casings can be machined completely with only two settings.

In-house facilities are designed to meet the performance and NPSH testing requirements of all pumps manufactured in the company in full compliance with API 610 Standards.

A quality assurance system certified in accordance with ISO 9001 ensures Gabbioneta pumps™ are of the highest quality.





**Trillium Pumps Italy S.r.l.**  
**Società Unipersonale**

Gaetana Agnesi 1, 20834 Nova Milanese (MB), Italy  
T: +39 0362 17331; Fax: +39 0362 1733209; E: [gabbioneta.sales@trilliumflow.com](mailto:gabbioneta.sales@trilliumflow.com)

[www.trilliumflow.com](http://www.trilliumflow.com) Certified: ISO 9001:2015, ISO 14001:2015, OHSAS 18001:2007